



Bedienungsanleitung User Manual



GMAW 315

MIG/MAG Schweißinverter / MIG/MAG Welding Inverter



1.0003.0540-E
V 2.3.22



Betriebsanleitung lesen!

Die Betriebsanleitung führt in den sicheren Umgang mit den Produkten ein.

- Betriebsanleitungen sämtlicher Systemkomponenten lesen!
- Unfallverhütungsvorschriften beachten!
- Länderspezifische Bestimmungen beachten!

IMPORTANT: Read this Owner's Manual Completely before attempting to use this equipment. Save this manual and keep it handy for quick reference. Pay particular attention to the safety instructions we have provided for your protection. Contact your distributor if you do not fully understand this manual.

Inhaltsverzeichnis

1. Allgemeines	3
2. Sicherheitsanweisung	4
3. Betriebsbedingungen und Arbeitsumgebung	7
4. Technische Beschreibung	7
5. Technische Daten	7
6. Einschaltdauer	8
7. Geräteübersicht	9
8. Kontrollpaneel	10
9. Schweißen	11
2 Takt / 4 Takt	11
Spot Modus	11
Slow Feed, Langsamer Vorschub	11
Burn Back, Drahrückbrand	11
Drossel	12
Schematischer Anschluss	12
10. Fehlerursachen - Behebung	13
11. Prüfen und Warten	14
12. Fehler Codes	15
13. Schematischer Schaltplan	16

Copyright © 2020 MK Trade GmbH, Wies, Österreich.

Die Inhalte dieser Bedienungsanleitung sind alleiniges Eigentum der Firma MK Trade GmbH.

Eine Weitergabe sowie Vervielfältigung dieses Dokuments, Verwertung und Mitteilung seines Inhalts sind verboten, soweit nicht ausdrücklich gestattet. Zuwiderhandlungen verpflichten zu Schadenersatz.

Technische Änderungen und Irrtümer vorbehalten.

1. Allgemeines



Alle Personen, die mit diesem Gerät arbeiten, das Gerät bedienen, Wartungs- und oder Instandhaltungsarbeiten am Gerät durchführen, müssen

- entsprechende Qualifikationen haben,
- Kenntnisse vom Schweißen haben,
- diese Bedienungsanleitung vollständig lesen,
- die für Ihr Land gültigen Vorschriften beachten und einhalten.

Bei Fehlbedienung, Missbrauch oder anderes besteht Gefahr für

- Leib und Leben des Bedieners und Dritte,
- Gerät und / oder Sachwerte.

Die Bedienungsanleitung ist ein Teil des Gerätes und ist ständig am Einsatzort des Gerätes aufzubewahren.

Die in Ihrem Land gültigen Unfallverhütungs- und Umweltschutzvorschriften sind zu beachten und einzuhalten.

Das Gerät wurde zum Zeitpunkt der Fertigung nach dem Stand der Technik und den gültigen Normen gefertigt.

Das Gerät ist ausschließlich für die am Typenschild angegebenen Schweißverfahren zu benutzen. Eine andere bzw. darüberhinausgehende Benutzung ist nicht erlaubt!

Das Gerät ist für den Betrieb in Industrie und Gewerbe ausgelegt.

Die Service und Wartungsintervalle sind verpflichtend einzuhalten!

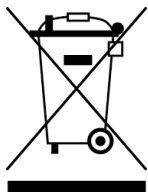

Entsorgung:

Werfen Sie dieses Gerät nicht in den Hausmüll!

Gemäß Europäischer Richtlinie über Elektro- und Elektronik-Altgeräte müssen verbrauchte, defekte oder nicht mehr Benutzte Elektrowerkzeuge getrennt gesammelt und einer umweltgerechten Wiederverwertung zugeführt werden, z.B. Altstoffsammelzentrum usw. Gerne können Sie dieses Gerät auch bei Ihrem Händler zurückbringen zur Fachgerechten Entsorgung

2. Sicherheitsanweisung



Die Anlage ist ausschließlich für das MIG/MAG Schweißen bestimmt. Das Bedienungspersonal muss über die Sicherheitshinweise unterrichtet werden. Die Anlage darf unter keinen Umständen von ungeschultem Personal bedient werden. Reparaturen im elektrischen Bereich dürfen nur von Elektrofachkräften ausgeführt werden. Bei Pflege-, Wartungs- und Reparaturarbeiten sowie vor Öffnen des Gehäuses immer Netzstecker ziehen. Die Anlage ist stets in einem funktionstüchtigen Zustand zu halten. Modifikationen an der Anlage führen zum Erlöschen der Betriebserlaubnis und der Gewährleistung. Die nachfolgend aufgeführten Sicherheitsbestimmungen sind zu beachten. Durch den Aktionsraum bedingt, sind in der Nähe arbeitende Personen, ebenfalls vor eventuellen Gefahren zu schützen.



Brennbare Stoffe sind von der Schweißzone fernzuhalten. Sie könnten sich durch Funken und heiße Schlacke entzünden.

Warnung:

Brennbare Materialien entfernen.
Heiße Metallteile und Schmelze abkühlen lassen.
Entflammare Bereiche zuerst entlüften.
Keine Behälter schweißen die brennbare Materialien enthalten (auch keine Reste davon; Gefahr entflammbarer Gase!)



Die Anlage nicht in Betrieb nehmen, wenn die Umgebungsluft explosiven Staub o. Gase enthält. Behälter bzw. Rohre, die sich im Über- bzw. Unterdruck befinden, dürfen nicht geschweißt werden. (Explosions- bzw. Implosionsgefahr!)
Beachten Sie eine erhöhte Brand- bzw. Explosionsgefahr.



Das Berühren stromführender Teile kann tödliche elektrische Schläge oder schwere Verbrennungen verursachen.



Beim Schweißen entsteht ein Stromkreis über die Elektrode, das Werkstück (alle damit verbundenen Teile) und das Massekabel, zurück in die Anlage. Dieser Stromkreis darf während des Schweißens nicht direkt berührt bzw. unterbrochen werden. Die Massezange muss mit einwandfreien metallischem Kontakt am Werkstück angebracht sein, im Nahbereich des zu schweißendem Teils.



Der Schweißstrom muss von der Elektrode über das Werkstück durch das Massekabel zurück in die Anlage fließen. Bei falscher Kontaktierung des Werkstück- bzw. Massekabels kann der Schweißstrom über eine indirekte Verbindung fließen und dort zu Schaden führen, z.B. über die Schutzleiter-Installation (PE, Erde).



Da der Bediener bei unsachgemäßem Gebrauch bzw. einem einfachen Defekt in Berührung kommen könnte, gelten erweiterte Sicherheitsmaßnahmen. Handschuhe und Schuhe sind zu tragen, die ausreichende Isolierung bieten. Die gesamte Kleidung ist trocken zu halten. Erhöhte Vorsicht gilt in einer Umgebung mit hoher Feuchtigkeit! Alle an der Anlage angeschlossenen elektrischen Leitungen sind auf einwandfreien Zustand zu überprüfen.

Warnung:

Blanke Stellen ohne bzw. mit schadhafter Isolierung sind lebensgefährlich.

Beschädigte Kabel bzw. Schlauchpakete sofort ersetzen!

Beim Wechsel der Brennteile die Anlage am Hauptschalter außer Betrieb setzen.

Vor öffnen des Anlagengehäuses durch ein Fachpersonal, Netzstecker ziehen. Die Anlagen sind in regelmäßigen Abständen auf Ihren einwandfreien Zustand zu prüfen.



Die Strahlung des Lichtbogens kann zu Augenschäden und Hautverbrennungen führen. Deshalb sollte zum Schutz der Augen ein Schweißhelm verwendet werden. Die Haut muss durch geeignete Schutzbekleidung (Schweißerhandschuhe, Lederschürze, Sicherheits-Schuhe) geschützt werden.

In der Nähe arbeitende Personen sind ebenfalls vor der Lichtbogenstrahlung zu schützen.



Beim Schweißen entstehen Rauchgase bzw. toxische Dämpfe. Deshalb darf das Schweißgerät nur in gut belüfteten Hallen, im Freien oder in geschlossenen Räumen mit starker Absaugung verwendet werden.

Der Schweißbereich des Werkstücks muss von Lösungs- und Entfettungsmitteln gereinigt werden, um die Bildung von Giftgasen zu vermeiden bzw. zu vermindern.

Schweißen von Blei, auch in Form von Überzügen, verzinkten Teilen, Kadmium, Beryllium und andere Metalle, die beim Schweißen giftige Dämpfe entwickeln, ist nur mit Atemschutzmaske und -gerät, sowie Absaugung und Filterung der giftigen Gase und Dämpfe erlaubt.

Erhöhte Vorsicht gilt beim Schweißen von Behältern, diese zuvor entleeren und sauber reinigen.

Warnung:

Entstehung von Rauchgasen bzw. toxischen Dämpfen kann zu Sauerstoffmangel in der Atemluft führen. Immer für ausreichend Frischluft sorgen!



Gasflaschen stehen unter hohem Druck und stellen eine Gefahren-Quelle dar. Der richtige Umgang mit ihnen ist unbedingt beim Gaslieferanten zu erfragen.



Beispielsweise müssen die Flaschen auf jeden Fall vor direkter Sonneneinstrahlung, vor offenem Feuer und starken Temperaturschwankungen, z. B. sehr tiefen Temperaturen geschützt werden. Gasbehälter und -zubehör sind in einwandfreiem Zustand zu halten.

Achtung:

Anschlüsse dürfen nicht mit Öl bzw. Fett geschmiert werden.

Neben den Hinweisen in dieser Betriebsanleitung sind die allgemeingültigen Sicherheitsvorschriften zu beachten, insbesondere die Unfallverhütungsvorschriften

Außerdem weisen wir darauf hin, dass die Anlage in bestimmten Einsatzbereichen trotz eingehaltener Aussendungsgrenzwerte elektromagnetische Störungen verursachen kann und dass diese Störungen im Verantwortungsbereich des Anwenders liegen.



Personen, die Herzschrittmacher oder Hörgeräte tragen, sollten sich vor Arbeiten in der Nähe der Maschinen, von einem Arzt beraten lassen.

Achtung:

Es ist möglich, dass im Bereich eines Krankenhauses oder ähnlichem durch den Betrieb der Anlage elektromedizinische, informationstechnische oder auch andere Geräte (EKG, PC, usw.) in ihrer Funktion beeinträchtigt werden können.

Vor Inbetriebnahme der Anlage ist daher sicherzustellen, dass Betreiber, die solche oder ähnliche Geräte betreiben, vorher informiert werden.



EMC Klasse A

Nur für die Nutzung im Industriellen Gebiet.

Folgen sie dieser Anweisung aufmerksam. Ein Missbrauch dieses Schweißgerätes kann zu Unfällen oder gar zum Tode führen.

1. Das Schweißgerät sollte nur an Stromquellen angeschlossen werden, die für dieses Gerät geeignet sind. Das Typenschild am Schweißgerät weißt diese Informationen auf. Bei der Nutzung im Freien, benutzen Sie bitte nur ein Verlängerungskabel das für den Gebrauch vorgesehen ist.
2. Benutzen sie das Gerät nur an trockenen Orten sowie auf Beton oder Steinboden. Der Raum sollte sauber und aufgeräumt bleiben.
3. Achten sie darauf dass sich keine brennbaren Stoffe in der Nähe des Gerätes befinden.
4. Tragen sie keine Kleidung die mit Fett oder Öl kontaminiert ist.
5. Die Kabel müssen von Fett oder Öl ferngehalten werden, und dürfen nicht in irgendwelcher Form um ihren Körper gebunden werden.
6. Arbeiten Sie sicher im Umgang mit den „Klemmen“ und Übernehmen Sie sich nicht.
7. Schalten sie das Gerät ab und ziehen den Stecker heraus wenn sie die Maschine justieren. Überprüfen sie das Gerät vor jeder Benutzung. Benutzen sie nur originale Ersatzartikel.
8. Folgen sie den Betriebsregeln beim betätigen der Schalter und bei Justierungen.
9. Tragen sie beim Schweißen Schutzkleidung. Dies beinhaltet: ein langärmeliges T-Shirt / Lederärmel, Schutzhose ohne Taschen, lange schützende Hosen, Arbeitsschuhe und Schutzbrille. Wenn sie mit heißem Material arbeiten, sollten sie Schutzhandschuhe tragen. Auch für Helfer gelten die gleichen Schutzmaßnahmen wie für Sie.
10. Tragen sie immer einen Schweißhelm mit schützendem Augenstück beim Schweißen. Fehler können Erblindung zur Folge haben. Tragen sie eine Schutzkappe unter dem Helm.
11. Wenn sie Überkopf schweißen, schützen sie sich vor herab fallendem heißen Metall. Schützen sie ihren Kopf, die Hände, die Füße und den Körper.
12. Ein Feuerlöscher sollte bei jeder Nutzung griffbereit sein.
13. Kinder sollten vom Arbeitsplatz ferngehalten werden. Wenn sie ihre Ausstattung lagern, achten sie darauf dass sich diese außerhalb der Reichweite von Kindern befindet.
14. Schützen sie sich vor einem elektrischen Schock. Arbeiten sie nicht bei Müdigkeit. Vermeiden sie Körperkontakt mit geerdeten Oberflächen.

Sicherheitshinweise:

Ein Stromschlag kann töten. Installation / Service und Instandhaltung darf nur von Fachpersonal durchgeführt werden. Bevor das Gehäuse geöffnet wird muss das Gerät vom Netz getrennt, und seit mindestens 5 min ausgeschaltet sein (damit die eingebauten Kondensatoren sich entladen können). Brennergarnitur in gepflegtem Zustand halten, dadurch wird die Gefahr eines Stromschlages vermieden.

Bitte beachten Sie auch die in Ihrem Land vorgeschriebenen Sicherheitsvorschriften!

3. Betriebsbedingungen und Arbeitsumgebung

Betriebsbedingungen:

- Spannung der Energiequelle: AC 400V
- Frequenz: 50 / 60 Hz
- zuverlässiger Erdungsschutz ist Voraussetzung.
- Höhe über dem Meeresspiegel \leq 1000 M

Arbeitsumgebung:

- Relative Feuchtigkeit $<$ 90% (durchschnittliche Temperatur 20°)
- Umgebungstemperatur: -10°C + 40°C
- Der Aufstellungsort des Schweißgerätes sollte frei von schädlichen Gasen, Chemikalien, explosivem, brennbarem oder ätzendem Stoffen sein und keine großen Erschütterungen oder Stößen ausgesetzt sein.
- Vermeiden Sie den Kontakt mit Wasser und schützen Sie das Gerät vor direkter Sonneneinstrahlung. Mit dem Gerät im Regen zu Arbeiten ist verboten.
- Neigungswinkel des Gerätes darf 15° nicht überschreiten.
- Das Gerät soll während der Funktionsdauer nicht eingengt oder direkt an einer Wand stehen, damit eine ausreichende Belüftung des Gerätes gewährleistet ist.

4. Technische Beschreibung

Das vorliegende Schweißgerät ist mit CE gekennzeichnet und entspricht den gültigen Normen (EMC 2014/30/EU & LVD 2014/35/EU, EN 60974-10:2014 + A1:2015, EN60974-1:2012).

Das GMAW 315 Schweißgerät besitzt die modernste IGBT Technologien. Es hat mehr Leistung und höhere Effektivität so dass es mit üblichen Transformator Schweißgeräten nicht vergleichbar ist. Der Schweißstrom ist sehr stabil. Das Schweißgerät hat hervorragende Eigenschaften bei Minimum - Strom. Die Schutzmaßnahmen des Schweißgeräts sind nahezu perfekt. Das Schweißgerät ist zuverlässig, leicht im Gewicht und einfach zu handhaben. Es ist besonders verwendbar für Personen die flexibel an vielen Orten arbeiten müssen.

5. Technische Daten

Parameter	Modell	GMAW 315
Eingangsstärke		3~380/400/440 \pm 10%, 50/60Hz
Einstellung des Schweißstrom (A)		50 – 315
Max. Eingangsleistung (KW)		11
Leerlaufspannung (V)		53
Schweißspannung (V)		13,5 - 30
Effizienz		\geq 85%
Einschaltdauer (40°C , 10 min.)		40% 315A 60% 250A 100% 200A
Power Factor		0,7
Isolationsklasse		IP23 H
Dimension (LxBxH) (mm)		618 x 240 x 445
Gewicht (Kg)		25

6. Einschaltdauer

Der Buchstabe „X“ steht für Einschaltdauer (Duty Cycle). Hierbei handelt es sich um den Teil der Zeit, in der ein Schweißgerät innerhalb eines bestimmten Zeitzyklus (10 Minuten) kontinuierlich mit seinem Ausgangsnennstrom schweißen kann.

Die Beziehung zwischen dem Arbeitszyklus "X" und dem Ausgangsschweißstrom "I" ist in der rechten Abbildung dargestellt.

Wenn das Schweißgerät überhitzt, sendet der IGBT-Überhitzungsschutz ein Signal an die Schweißgerät Steuereinheit zum Abschalten des Ausgangsschweißstroms und gleichzeitig leuchtet die Überhitzungs Kontrolllampe an der Frontplatte. In diesem Fall sollte die Maschine 10 - 15 Minuten lang nicht schweißen, um sich mit dem Lüfterlauf abzukühlen. Bei erneutem Betrieb der Maschine sollte der Schweißausgangsstrom oder der Arbeitszyklus reduziert werden.

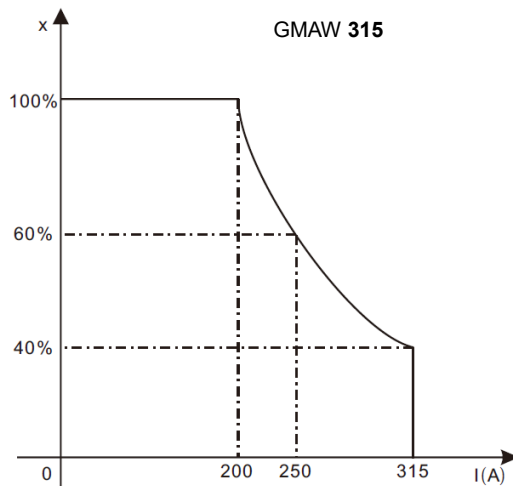

7. Geräteübersicht

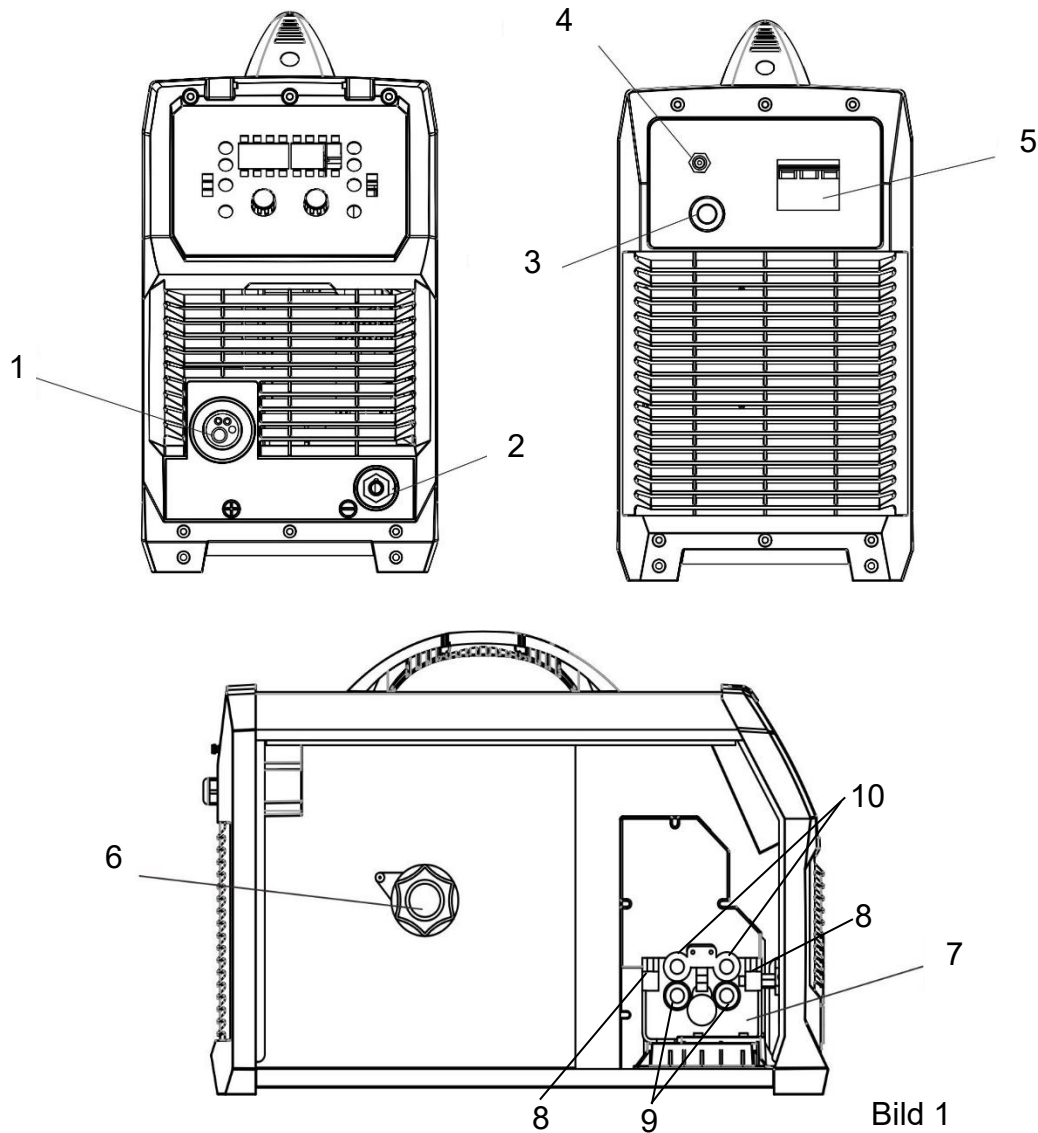

- 1. Euro Zentral Anschluss
- 2. Ausgang MINUS (-)
- 3. Netzkabel
- 4. Gas Eingang
- 5. Ein / Aus Schalter
- 6. Drahtrollen Halter
- 7. Drahtvorschubeinheit
- 8. Spansschraube
- 9. Vorschubrolle
- 10. Anpressrolle

Die Vorschubrollen der Vorschubeinheit müssen dem Drahtdurchmesser angepasst werden. Hierfür können diese umgedreht bzw. durch passende Rollen mit passendem Durchmesser bzw. Form ersetzt werden.

8. Kontrollpaneel



Bild 2

- 1 Spannungs Parameter LED (Symbolisiert, der Wert im Display wird in Volt angezeigt)
- 2 Power LED
- 3 Alarm LED
- 4 Sekunden Parameter LED (Symbolisiert, der Wert im Display wird in Sekunden angezeigt)
- 5 Display, Schweißspannung, im Schweißvorgang wird die tatsächliche Spannung angezeigt.
- 6 Drahtvorschub Parameter LED (Symbolisiert, der Wert im Display wird in m/min angezeigt)
- 7 2 Takt / 4 Takt / Spot Modus
- 8 Gastest Taster (durch drücken kann das Gasventil geöffnet werden)
- 9 Einstell Regler
- 10 Drahtvorschub Regler
- 11 Drahtvorschub Taster (durch drücken wird der Drahtvorschub aktiviert)
- 12 Langsamer Vorschub /Drahrückbrand / Drossel Parameter
- 13 Ampere LED (Symbolisiert, der Wert im Display wird in Ampere angezeigt)
- 14 Display, Drahtvorschubgeschwindigkeit m/min, Schweißstrom, im Schweißvorgang werden die Ampere angezeigt.

Alarm LED (3):

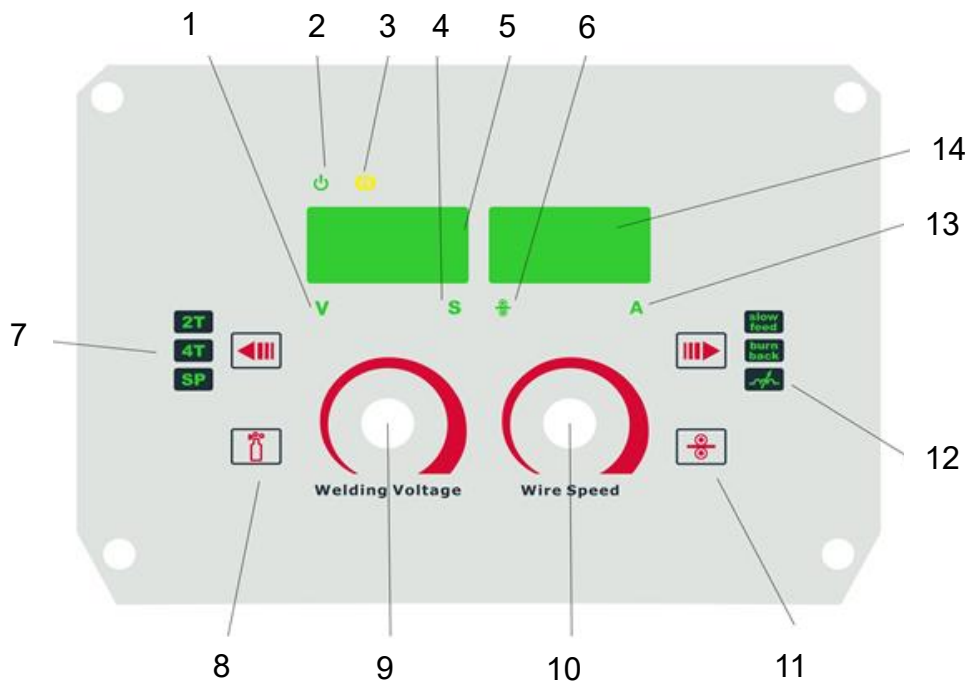

Sollte das Gerät Überhitzen wird der Schweißvorgang Automatisch unterbrochen, die Kontroll LED Leuchtet auf.

Gerät abkühlen lassen bis die LED erlischt, danach kann der Schweißprozess erst fortgeführt werden.

9. Schweißen

Die Gewünschte Schweißspannung wird mit dem Drehregler 9 (Bild 2) eingestellt.
Die Drahtvorschubgeschwindigkeit wird mit dem Drehregler 10 (Bild 2) eingestellt.

Der Schweißstrom ist abhängig von der Eingestellten Schweißspannung und der Drahtvorschubgeschwindigkeit, während dem Schweißvorgang, leuchtet die Ampere LED 13 (Bild 2) und der Aktuelle Schweißstrom wird am Display 14 (Bild 2) angezeigt.

2 Takt / 4 Takt

Durch Drücken der Pfeiltaste 7 (Bild 2) kann der Gewünschte Modus 2 T oder 4T) ausgewählt werden. Der eingestellte Modus wird durch Leuchten des jeweiligen LED's signalisiert.

Spot Modus

Durch Drücken der Pfeiltaste 7 (Bild 2) bis die LED „SP“ leuchtet wird die Spot Funktion Aktiviert.

Durch Drücken des Einstellreglers 9 (Bild2) gelangt man zu folgenden Einstellwerten:

„SPT“ (wird im Display 5 Bild 2 angezeigt) Dauer der Pause in Sekunden, durch erneutes drücken gelangt man zum nächsten Einstellwert.

„OPT“ (wird im Display 5 Bild 2 angezeigt) Spot Dauer, Lichtbogen Dauer in Sekunden, durch erneutes drücken leuchtet die Spannungs LED 1 (Bild 2) auf, wird der Einstellregler erneut gedrückt gelangt man wieder zum ersten Einstellwert „SPT“.

Ist man bei dem Einstellwert „SPT“ (wird im Display 5 Bild 2 angezeigt), kann dieser Wert durch Drehen des Einstellreglers 10 (Bild 2) eingestellt werden, hier kann die Dauer der Pause eingestellt werden in Sekunden.

Beim Einstellwert „OPT“ (wird im Display 5 Bild 2 angezeigt) wird die Dauer des Schweißintervalls eingestellt, in Sekunden.

Beispiel:

„SPT“ = 1 sek. (Pause Zeit)

„OPT“ = 1,5 sek (Schweißdauer Zeit)

Drückt man den Brennergastaster startet der Lichtbogen für „1,5“ Sekunde danach ist „1“ Sekunden Pause bis der Lichtbogen erneut startet, dieser Vorgang wiederholt sich solange bis man den Brennergastaster loslässt.

Slow Feed, Langsamer Vorschub

Drücken Sie die Pfeiltaste 12 (Bild 2) solange bis die LED „slow feed“ aufleuchtet.

Wenn diese LED leuchtet kann der Langsame Drahtvorschub (Wert in Sekunden) mittels drehen des Einstellreglers eingestellt werden.

Funktion / Wirkung:

Bei aktivem „slow feed“ startet das Gerät mit einer geringeren Drahtvorschubgeschwindigkeit und erhöht den Vorschub langsam (abhängig von der eingestellten Zeit) auf die eingestellte Drahtvorschubgeschwindigkeit. Somit wird beim Start weniger Draht gefördert und die Übernaht wird somit geringer beim Beginn der Schweißnaht.

Burn Back, Drahrückbrand

Drücken Sie die Pfeiltaste 12 (Bild 2) solange bis die LED „burn back“ aufleuchtet.

Wenn diese LED leuchtet kann der Drahrückbrand mittels drehen des Einstellreglers eingestellt werden.

Funktion / Wirkung:

Mit dieser Funktion kann der Rückbrand des Drahtes in den Brenner nach Beendigung des

Schweißvorganges eingestellt werden. Bei Erhöhung dieses Wertes brennt der Draht nicht mehr so weit in den Brenner zurück nach Beendigung des Schweißvorganges.

Drossel

Drücken Sie die Pfeiltaste 12 (Bild 2) solange bis die LED „“ aufleuchtet. Wenn diese LED leuchtet kann die Drosselfunktion mittels drehen des Einstellreglers eingestellt werden.

Funktion / Wirkung:

Mit dieser Funktion kann das Schweißbad eingestellt werden, der wert kann von -5 bis +5 stufenlos eingestellt werden. min-5 = Harter Lichtbogen, max. +5 = weicher Lichtbogen.

Bei einem Härteren Lichtbogen entstehen mehr Schweißspritzer, dafür ist der Lichtbogen schmaler als beim weichen Lichtbogen.

Beim einem Weicheren Lichtbogen entstehen geringere Schweißspritzer, der Lichtbogen und das Schweißbad wird breiter.

Schematischer Anschluss

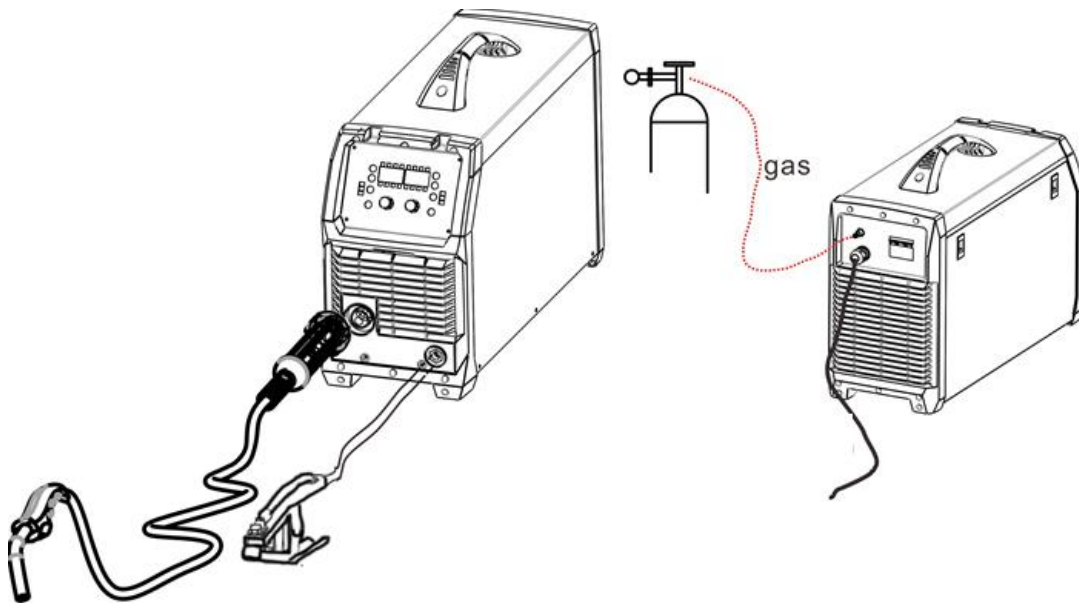

10. Fehlerursachen - Behebung

Fehler	Mögliche Ursache	Behebung
Netz angeschlossen und Netzschalter auf „I“ – Kontrollleuchte Netz leuchtet nicht	Netzsicherung hat ausgelöst	Netzsicherung prüfen
	Netzanschluss unterbrochen	Netzanschluss prüfen
Alarmleuchte leuchtet	Gerät ist Überhitzt	Der Alarm wird nach Ablauf der Lüfterkühlung freigegeben und Sie können das Gerät neu starten
	Überstrom	Die Alarmleuchte leuchtet kontinuierlich. Schließen Sie den Netzstecker an eine passende, in den Technischen Daten angegebene Stromquelle, an
	Einschaltdauer wird überschritten	Der Alarm wird nach Ablauf der Lüfterkühlung freigegeben und Sie können das Gerät neu starten. Kürzere Arbeitszyklen einhalten
Beim Drücken des Brenntasters keine Funktion vorhanden	Brenntaste defekt	Schlauchpaket wechseln
Kein stabiler Lichtbogen	Massekabel nicht angeschlossen oder schlechten Kontakt	Massekabel am Werkstück anschließen bzw. Kontakt verbessern
	Eingestellter Schweißstrom oder Drahtzufuhr zu niedrig oder zu hoch	Schweißstrom und Drahtzufuhr nach Erfordernis anpassen
Kein Schutzgas – im Betrieb Gas Ventil „Klick“ hörbar	Gasflasche leer oder nicht aufgedreht	Gasflasche aufdrehen bzw. füllen lassen
	Gasdurchfluss zu gering	Gasdruckregler einstellen
	Gaszuleitung geknickt	Kontrolle Gasleitung
Zu Geringer Einbrand	Schweißgeschwindigkeit zu hoch	Schweißgeschwindigkeit reduzieren
	Schweißstrom zu gering	Schweißstrom anpassen
Schweißvorgang wird unterbrochen und die Alarm LED leuchtet	Überhitzungsschutz im Gerät hat ausgelöst	Gerät mit Lüfter abkühlen lassen
Draht klebt an der Stromdüse fest	Zu geringer Vorschub m/min eingestellt	Vorschubgeschwindigkeit erhöhen
	Seele im Schlauchpaket defekt, geknickt	Seele bzw. Schlauchpaket wechseln
	Anpressdruck beim Drahtvorschub zu fest eingestellt	Anpressdruck anpassen
	Anpressdruck beim Drahtvorschub zu leicht eingestellt	Anpressdruck anpassen
	Falsche Vorschubrolle	Vorschubrolle anpassen
Draht verwickelt sich bei der Vorschubeinheit	Anpressdruck zu fest eingestellt	Anpressdruck anpassen

11. Prüfen und Warten

Intervall	Zu Prüfen
Täglich	<ul style="list-style-type: none">- Das Netzkabel, Verbindungskabel auf Beschädigungen Prüfen. (bei defekt autorisiertes Fachpersonal kontaktieren).- Massekabel, Schlauchpaket, Elektrodenhalter auf Beschädigungen Prüfen und bei Bedarf wechseln.- Gerät auf äußere Beschädigungen Prüfen.- Ein/ Ausschalter auf Beschädigung Prüfen. (bei defekt autorisiertes Fachpersonal kontaktieren).- Auffällige Geräusche nach dem Einschalten z.B.: verschmutzter Lüfter (kann der Fehler durch Reinigen/ Ausblasen nicht beseitigt werden wenden Sie sich an ein autorisiertes Fachpersonal).
Monatlich	<ul style="list-style-type: none">- Das Gerät mit trockene Luft Ausblasen und Reinigen.
Jährlich	<ul style="list-style-type: none">- Isolationsmessung Service und Kalibration des Gerätes. Bei nicht Durchführung erlischt die Garantie. (Durchführung nur durch einem vom Hersteller autorisiertem Fachpersonal)

Jegliche Arbeiten im und am Gerät, Änderungen usw. dürfen nur durch ein Autorisiertes Fachpersonal durchgeführt werden, ansonsten kann es zum Verfall der Zulassung führen und auch zum Erlöschen der Garantie / Gewährleistung. Auch das Tauschen des Steckers, Netzkabel darf nur durch ein Autorisiertes Fachpersonal durchgeführt werden!

Es dürfen nur Original Ersatzteile verwendet werden.

12. Fehler Codes

Fehler Typ	Fehler Code	Beschreibung	LED Status
Temperatur/ Überhitzung	E01	Überhitzung (Erstes Thermo Relais)	Gelbe LED (Überhitzungsschutz) Dauerlicht
	E02	Überhitzung (Zweites Thermo Relais)	Gelbe LED (Überhitzungsschutz) Dauerlicht
	E03	Überhitzung (Drittes Thermo Relais)	Gelbe LED (Überhitzungsschutz) Dauerlicht
	E04	Überhitzung (Viertes Thermo Relais)	Gelbe LED (Überhitzungsschutz) Dauerlicht
	E09	Überhitzung	Gelbe LED (Überhitzungsschutz) Dauerlicht
Schweißgerät	E10	Phase fehlt	Gelbe LED Dauerlicht
	E11	Kein Wasser/ Error Wasserkühler	Gelbe LED Dauerlicht
	E12	Kein Gas	Rote LED Dauerlicht
	E13	Unter Spannung	Gelbe LED Dauerlicht
	E14	Über Spannung	Gelbe LED Dauerlicht
	E15	Über Strom	Gelbe LED Dauerlicht
	E16	Drahtvorschub überlstet	
Schalter	E20	Tastenfehler am Bedienfeld beim Einschalten der Maschine	Gelbe LED Dauerlicht
	E21	Andere Störungen am Bedienfeld beim Einschalten der Maschine	Gelbe LED Dauerlicht
	E22	Brennerfehler beim Einschalten der Maschine	Gelbe LED Dauerlicht
	E23	Brennerfehler während des normalen Betriebs	Gelbe LED Dauerlicht
Zubehör	E30	Schneid Brenner nicht Angeschlossen (nur für Plasmaschneider)	Rote LED blinkt
	E31	Wasserkühler nicht Angeschlossen	Gelbe LED Dauerlicht
Communication	E40	Verbindungsproblem zwischen Grundgerät und Vorschubeinheit	
	E41	Kommunikationsfehler	

13. Schematischer Schaltplan

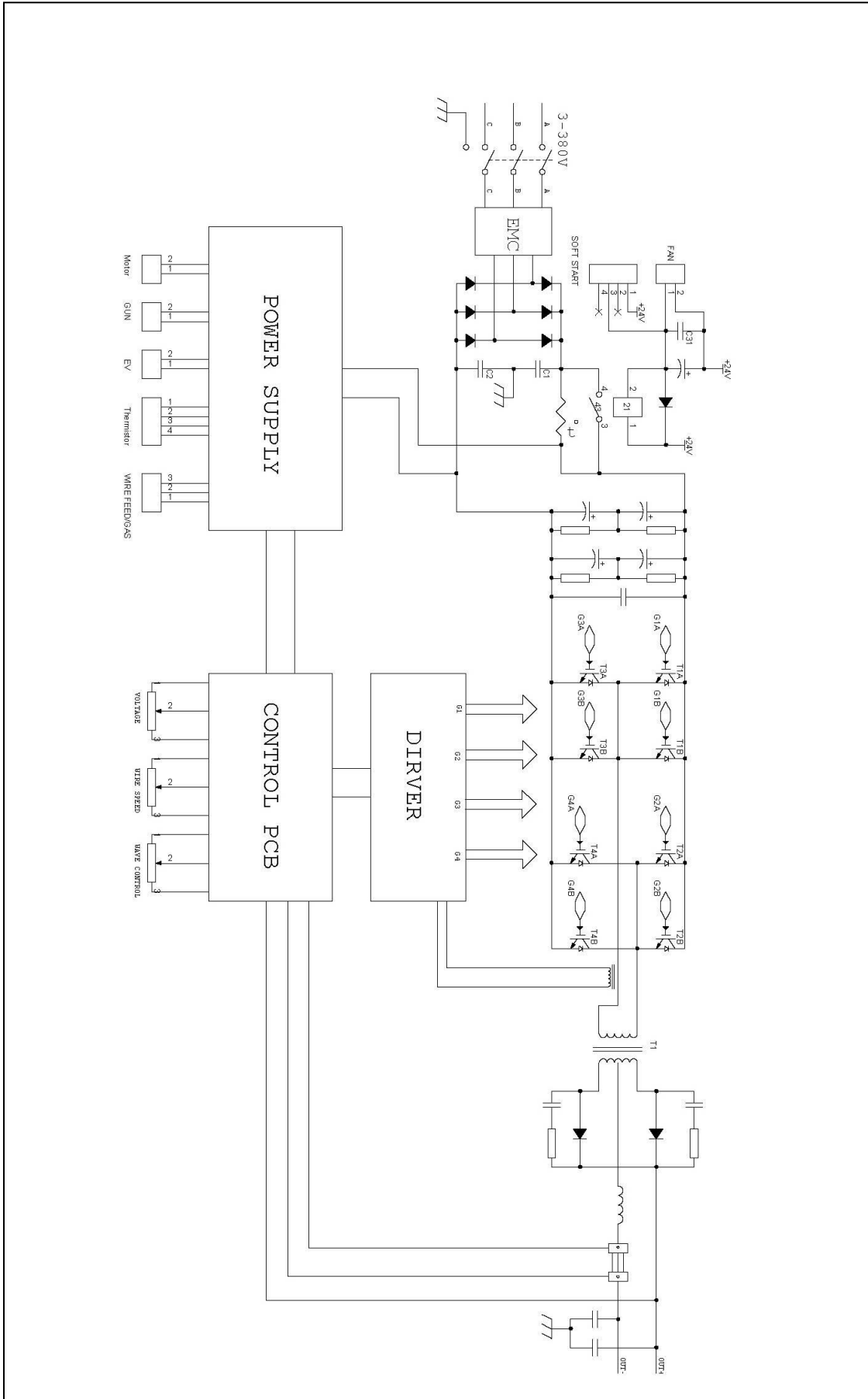

CONTENT

§1 Safety	1
§1.1 Symbols Explanation	1
§1.2 Machine Operating warnings!	1
§1.3 EMC device classification	8
§1.4 EMC measure	8
§1.5 Warning label	10
§2 Overview	11
§2.1 Brief Introduction	11
§2.2 Working Principle.....	12
§2.3 Volt-Ampere Characteristic	12
§2.4 Principles of welding.....	13
§3 Installation and Adjustment	14
§3.1 Parameters	14
§3.2 Duty cycle and Over-heat.....	14
§3.3 Equipment Connection	15
§3.4 Maintenance of MIG Gun mechanism.....	16
§3.4.1 Dissection graphics for the MIG GUN.....	16
§3.4.2 Parts list for the MIG GUN	16
§3.4.3 the operation for the MIG GUN	17
§4 Operation	19
§4.1 Layout for the front and rear panel	19
§4.2 Wire Feeder of welding machine	21
§4.3 Welding operation	22
§4.3.1 Wire Feed Roller Selection	25
§4.3.2 Wire Installation and Set Up Guide.....	26
§4.3.3 MIG Torch Liner Installation	29
§4.3.4 MIG Torch Liner Types and Information	31

CONTENT

<i>§4.3.5 Torch & Wire Feed Set Up for Aluminium Wire</i>	33
<i>§4.3.6 MIG Welding</i>	36
<i>§4.4 Welding parameters</i>	44
<i>§4.5 Operation environment</i>	46
<i>§4.6 Operation Notices</i>	46
§5 Maintenance & Troubleshooting	47
<i>§5.1 Maintenance</i>	47
<i>§5.2 Troubleshooting</i>	48
<i>§5.3 List of error code</i>	50
<i>§5.4 Electrical schematic drawing</i>	51

Copyright © 2020 MK Trade GmbH, Wies, Austria

The contents of these User Manual are the sole property of the company MK Trade GmbH.

Passing on as well as copying of this document, the use and distribution of its content are prohibited if not explicitly permitted. Contraventions are liable to compensation.

Subject to technical modifications and error.

§1 Safety

Welding and cutting equipment can be dangerous to both the operator and people in or near the surrounding working area, if the equipment is not correctly operated. Equipment must only be used under the strict and comprehensive observance of all relevant safety regulations. Read and understand this instruction manual carefully before the installation and operation of this equipment.

§1.1 Symbols Explanation



- The above symbols mean warning!

Notice! Running parts, getting an electric shock or making contacts with thermal parts will cause damage to your body and others. The underline message is as follows:

Welding is quite a safe operation after taking several necessary protection measures!

§1.2 Machine Operating warnings!

- The following symbols and words explanations are for some damages to your body or others, which could happen during the welding operation. While seeing these symbols, please remind yourself and others to be careful.
- Only people who are trained professionally can install, debug, operate, maintain and repair the welding equipment covered with this Operator's Manual!
- During the welding operation, non-concerned people should NOT be around, especially children!
- After shutting off the machine power, please maintain and examine the equipment according to §7 because of the DC voltage existing in the electrolytic capacitors at the output of the power supply!

SAFETY



ELECTRIC SHOCK CAN KILL.

Touching live electrical parts can cause fatal shocks or severe burns. The electrode and work circuit is electrically live whenever the output is on. The input power circuit and internal machine circuits are also live when power is on. In Mig/Mag welding, the wire, drive rollers, wire feed housing, and all metal parts touching the welding wire are electrically live. Incorrectly installed or improperly grounded equipment is dangerous.

- Never touch live electrical parts.
- Wear dry, hole-free gloves and clothes to insulate your body.
- Be sure to install the equipment correctly and ground the work or metal to be welded to a good electrical (earth) ground according to the operation manual.
- The electrode and work (or ground) circuits are electrically “hot” when the machine is ON. Do not touch these “hot” parts with your bare skin or wet clothing. Wear dry, hole-free gloves to insulate hands.
- In semiautomatic or automatic wire welding, the electrode, electrode reel, welding head, nozzle or semiautomatic welding gun are also electrically “hot”.
- Insulate yourself from work and ground using dry insulation. Make certain the insulation is large enough to cover your full area of physical contact with work and ground.
- Be Careful when using the equipment in small places, falling-off and wet circumstance.
- Always be sure the work cable makes a good electrical connection with the metal being welded. The connection should be as close as possible to the area being welded.
- Maintain the electrode holder, work clamp, welding cable and welding machine in good, safe operating condition. Replace damaged insulation.
- Never dip the electrode in water for cooling.
- Never simultaneously touch electrically “hot” parts of electrode holders connected to two welders because voltage between the two can be the total of the open circuit voltage of both welders.

SAFETY

- When working above the floor level, use a safety belt to protect yourself from a fall should you get an electric shock!



FUMES AND GASES CAN BE DANGEROUS.

Smoke and gas generated whilst welding or cutting can be harmful to people's health. Welding produces fumes and gases. Breathing these fumes and gases can be hazardous to your health.

- Do not breathe the smoke and gas generated whilst welding or cutting, keep your head out of the fumes. Use enough ventilation and/or exhaust at the arc to keep fumes and gases away from the breathing zone. When welding with electrodes which require special ventilation such as stainless or hard facing or on lead or cadmium plated steel and other metals or coatings which produce highly toxic fumes, keep exposure as low as possible and below the Threshold Limit Values using local exhaust or mechanical ventilation. In confined spaces or in some circumstances, outdoors, a respirator may be required. Additional precautions are also required when welding on galvanized steel.
- Do not weld in locations near chlorinated hydrocarbon vapors coming from degreasing, cleaning or spraying operations. The heat and rays of the arc can react with solvent vapors to form phosgene, a highly toxic gas, and other irritating products.
- Shielded gases used for arc welding can displace air and cause injury or death. Always use enough ventilation, especially in confined areas, to insure breathing air is safe.
- Read and understand the manufacturer's instructions for this equipment and the consumables to be used, including the material safety data sheet and follow your employer's safety practices.



ARC RAYS: Harmful to people's eyes and skin.

Arc rays from the welding process produce intense visible and invisible ultraviolet and

SAFETY

infrared rays that can burn eyes and skin.

- Use a shield with the proper filter and cover plates to protect your eyes from sparks and the rays of the arc when welding or observing open arc welding.
- Use suitable clothing made from durable flame-resistant material to protect your skin and that of your coworkers from the arc rays.
- Protect other nearby personnel with suitable, non-flammable screening and /or warn them not to watch the arc nor expose themselves to the arc rays or to hot spatter or metal.



SELF-PROTECTION

- Keep all equipment safety guards, covers and devices in position and in good repair. Keep hands, hair, clothing and tools away from V-belts, gears, fans and all other moving parts when starting, operating or repairing equipment.
- Do not put your hands near the engine fan. Do not attempt to override the governor or idler by pushing on the throttle control rods while the engine is running.



DO NOT add any fuel near an open-flame welding arc or when the engine is running. Stop the engine and allow it to cool before refueling to prevent spilled fuel from vaporizing on contact with hot engine parts and igniting. Do not spill fuel when filling tank. If fuel is spilled, wipe it up and do not start engine until fumes have been eliminated.



WELDING SPARKS can cause fire or explosion.

Welding on closed containers, such as tanks, drums, or pipes, can cause them to explode. Flying sparks from the welding arc, hot work piece, and hot equipment can cause fires and burns. Accidental contact of electrode to metal objects can cause sparks,

SAFETY

explosion, overheating, or fire. Check and be sure the area is safe before doing any welding

- Remove fire hazards material from the welding area. If this is not possible, cover them to prevent the welding sparks from starting a fire. Remember that welding sparks and hot materials from welding can easily go through small cracks and openings to adjacent areas. Avoid welding near hydraulic lines. Have a fire extinguisher readily available.
- Where compressed gases are to be used at the job site, special precautions should be used to prevent hazardous situation.
- When not welding, make certain no part of the electrode circuit is touching the work or ground. Accidental contact can cause overheating and create a fire hazard.
- Do not heat, cut or weld tanks, drums or containers until the proper steps have been taken to insure that such procedures will not cause flammable or toxic vapors from substances inside. They can cause an explosion even though they have been “cleaned”.
- Vent hollow castings or containers before heating, cutting or welding. They may explode.
- Sparks and spatter are thrown from the welding arc. Wear oil free protective garments such as leather gloves, heavy shirt, cuff less trousers, high shoes and a cap over your hair. Wear earplugs when welding out of position or in confined places. Always wear safety glasses with side shields when in a welding area.
- Connect the work cable to the work as close to the welding area as practical. Work cables connected to the building framework or other locations away from the welding area increase the possibility of the welding current passing through lifting chains, crane cables or other alternate circuits. This can create fire hazards or overheat lifting chains or cables until they fail.



Rotating parts may be dangerous.

- Use only compressed gas cylinders containing the correct shielding gas for the process used and properly operating regulators designed for the gas and pressure used.

SAFETY

All hoses, fittings, etc. should be suitable for the application and maintained in good condition.

- Always keep cylinders in an upright position securely chained to an undercarriage or fixed support.
- Cylinders should be located:
 - Away from areas where they may be struck or subjected to physical damage.
 - At a safe distance from arc welding or cutting operations and any other source of heat, sparks, or flame.
- Never allow the electrode, electrode holder or any other electrically “hot” parts to touch a gas cylinder.
- Keep your head and face away from the cylinder valve outlet when opening the cylinder valve.
- Valve protection caps should always be in place and hand tight except when the cylinder is in use or connected for use.



Gas Cylinders.

Shielding gas cylinders contain gas under high pressure. If damaged, a cylinder can explode. Because gas cylinders are normally part of the welding process, be sure to treat them carefully. CYLINDERS can explode if damaged.

- Protect gas cylinders from excessive heat, mechanical shocks, physical damage, slag, open flames sparks, and arcs.
- Insure cylinders are held secure and upright to prevent tipping or falling over.
- Never allow the welding electrode or earth clamp to touch the gas cylinder, do not drape welding cables over the cylinder.
- Never weld on a pressurised gas cylinder, it will explode and kill you.
- Open the cylinder valve slowly and turn your face away from the cylinder outlet valve and gas regulator.

SAFETY



Gas build up.

The build up of gas can cause a toxic environment, deplete the oxygen content in the air resulting in death or injury. Many gases used in welding are invisible and odourless.

- Shut off shielding gas supply when not in use.
- Always ventilate confined spaces or use approved air-supplied respirator.



Electric and Magnetic Fields.

Electric current flowing through any conductor causes localized Electric and Magnetic Fields (EMF). The discussion on the effect of EMF is ongoing in the entire world. Up to now, no material evidence shows that EMF may have effects on health. However, the research on the effect of EMF is still ongoing. Before any conclusion, we should minimize exposure to EMF as far as possible.

In order to minimize EMF, we should use the following procedures:

- Route the electrode and work cables together – Secure them with tape when possible.
- All cables should be put away and far from the operator.
- Never coil the power cable around your body.
- Make sure welding machine and power cable to be far away from the operator as far as possible according to the actual circumstance.
- Connect the work cable to the workpiece as close as possible to the area being welded.
- The people with heart-pacemaker should be away from the welding area.



Noise can damage hearing.

Noise from some processes or equipment can damage hearing. You must protect your ears from loud noise to prevent permanent loss of hearing.

- To protect your hearing from loud noise, wear protective ear plugs and/or ear muffs.

SAFETY

Protect others in the workplace.

- Noise levels should be measured to be sure the decibels (sound) do not exceed safe levels.



Items being welded generate and hold high heat and can cause severe burns. Do not touch hot parts with bare hands. Allow a cooling period before working on the welding gun. Use insulated welding gloves and clothing to handle hot parts and prevent burns.

§1.3 EMC device classification



Radiation Class A Device.

- Only can be used in the industrial area
- If it is used in other area, it may cause connection and radiation problems of circuit.

Radiation Class B device.

- It can meet the radiation requirements of residential area and industrial area. It also can be used in residential area which power is supplied by public low voltage circuit.

EMC device can be classified by power nameplate or technical data.

hanker welding machines belong to Class A.

§1.4 EMC measure



In the special situation, The specified area may be affected, the standard of radiation limit value has been complied with (eg: The device, which is easy effected by electromagnetism, is used at the installation location, or there is radio or TV near the installation location). In this condition, the operator should adopt some appropriate measures to remove interference. Accoring to the domestic and international standards, the ambient devices' electromagnetism situation and anti-interference ability must be checked:

SAFETY

- Safety device
- Power line, Signal transmission line and Data transmission line
- Data processing equipment and telecommunication equipment
- Inspection and calibration device

The effective measures avoid the problem of EMC:

a) Power source

Even though the power source connection meet rules, we still need to take additional measure to remove the electromagnetic interference. (eg: Use the right power filter.)

b) The welding line

- Try to shorten the length of cable
- Put the cable together
- Be Far away from other cable

c) Equipotential connection

d) Ground connection of work-piece

- When necessary, use appropriate capacitance to connect the ground.

e) Shielding, when necessary

- Shield the ambient devices
- Shield the whole welding machine

SAFETY

§1.5 Warning label

The device with a warning label. **Do not remove, destroy or cover this label.** These warnings are intended to avoid incorrect device operations that could result in serious personal injury or property damage.

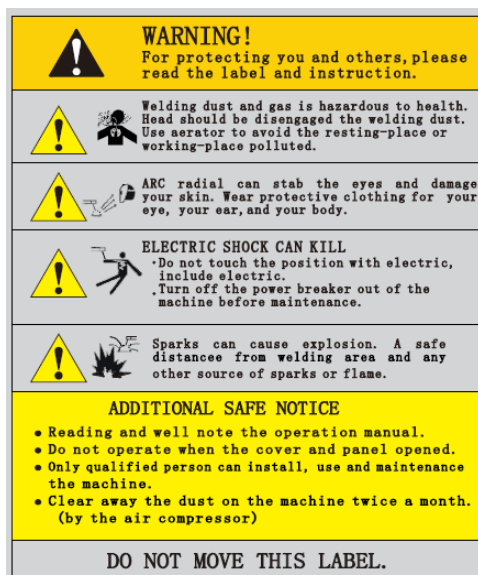

§2 Overview

§2.1 Brief Introduction

MIG series of welding machines adopts the latest Pulse Width Modulation (PWM) technology and the Insulated Gate Bipolar Transistor (IGBT) power modules. It uses switching frequencies in the 20KHz-50KHz range so as to replace the traditional line-frequency transformer type welding machines. Thus, machines are characterized with excellent dynamic response, portability, small size, lightweight, low energy consumption, etc.

MIG series of welding machines uses Mix gases as shielding gas to realize gas shielded welding, active gas (Ar+O₂, Ar+CO₂) as shielded gas to realize MAG welding and inactive gas (Ar) as shielded gas to realize MIG welding.

MIG series of welding machines has built-in automatic protection functions to protect the machines from over-voltage, over-current and over-heat. If any one of the above problems happens, the alarm lamp on the front panel will be lit and output current will be shut off automatically for the machine to protect itself and prolong the equipment using life.

MIG series Features:

1. Digital control system, real-time display the welding parameters;
2. High performance multifunction power source (MIG/MAG);
3. Waveform control, stable welding arc;
4. IGBT technology, low power consumption;
5. Rated Duty Cycle:

MIG 315 = 315A @ 40%(40°C)

MIG series of welding machine is suitable for all positions welding for various plates made of stainless steel, carbon steel, alloyed steel etc. Applications applied to pipe installment, petrochemical, architecture equipment, car repair, bicycle repair, handicraft and common steel fabrication.

MAG = Metal Active Gas Welding

MIG = Metal Inert Gas Welding

OVERVIEW

§2.2 Working Principle

The working principle of MIG series arc welding machine is shown as the following figure. Three-phase 380V work frequency AC is rectified into DC (530V), then is converted to medium frequency AC (about 20KHz) by inverter device (IGBT), after reducing voltage by medium transformer (the main transformer) and rectifying by medium frequency rectifier (fast recovery diodes), and is outputted by inductance filtering. when MIG. Meanwhile, the welding current parameter can be adjusted continuously and infinitely to meet with the requirements of welding craft.

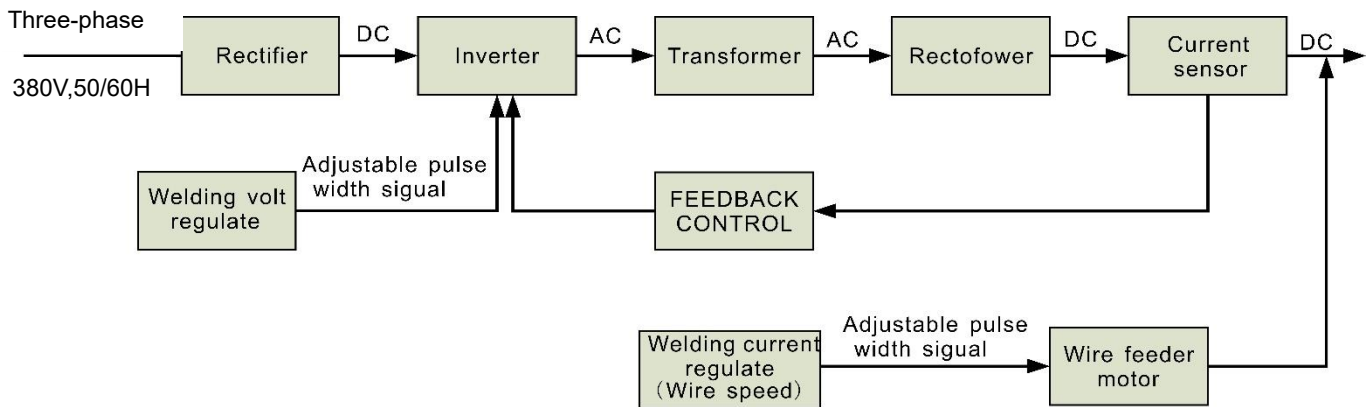

§2.3 Volt-Ampere Characteristic

MIG series welding machine has an excellent volt-ampere characteristic, whose graph is shown as the following figure. The relation between the rated loading voltage U_2 and welding current I_2 is as follows: $U_2=14+0.05I_2(V)$

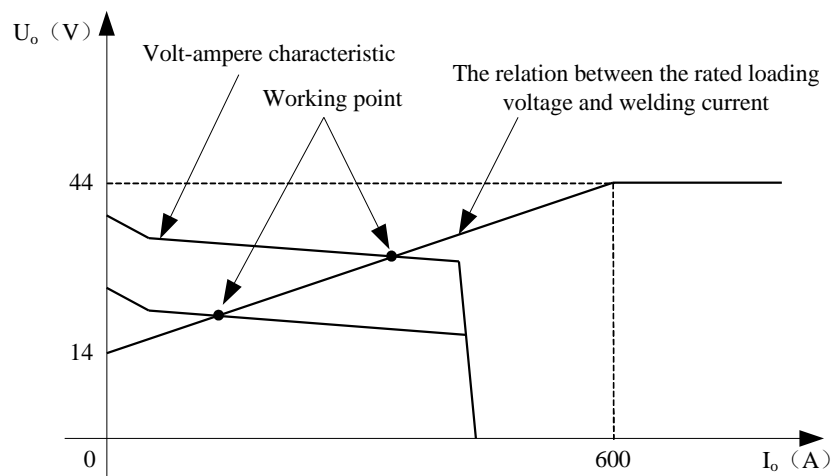

§2.4 Principles of welding

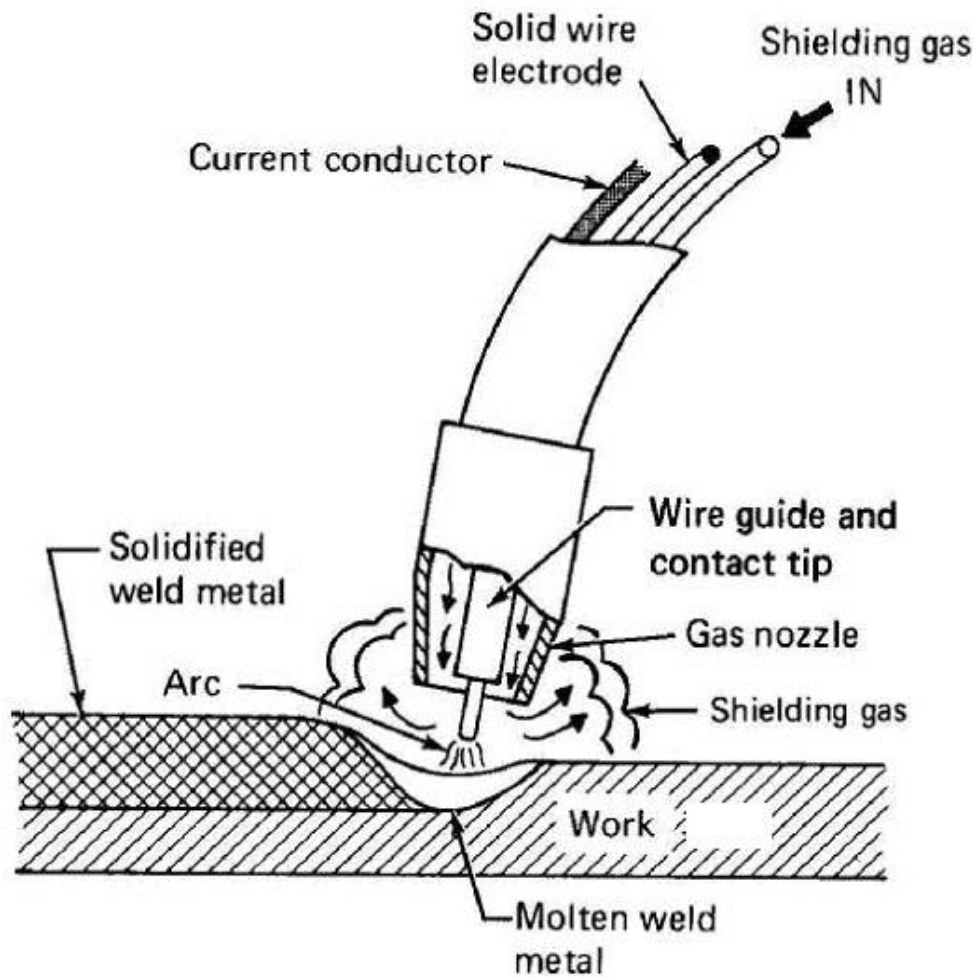

§3 Installation and Adjustment

§3.1 Parameters

Models	GMAW 315
Parameters	
Input Voltage (V)	3~380/400/440±10%
Frequency (HZ)	50/60
Input Current (A)	23
Input Power (KW)	11
Welding Current (A)	50-315
Welding Voltage (V)	13.5-30
No-load Voltage (V)	53
Duty cycle (40°C)	40% 315A 60% 250A 100% 200A
Diameter (mm)	Fe:0.6/0.9/1.0/1.2 SS:0.8/0.9/1.0/1.2 Flux-Cored:0.6/0.8/0.9/1.0/1.2
Protection class	IP23
Insulation class	H
Dimensions (mm)	
Weight (Kg)	25
Power Factor	0.7

Note: The above parameters are subject to change with future machine improvement!

§3.2 Duty cycle and Over-heat

The letter “X” stands for Duty Cycle, which is defined as the portion of the time a welding machine can weld continuously with it’s rated output current within a certain time cycle (10 minutes).

The relation between the duty cycle “X” and the output welding current “I” is shown as the right figure.

If the welding machine is overheating, the IGBT over-heat protection sensing will send a signal to the welding machine control unit to cut the output welding current OFF and light the over-heat pilot lamp on the

front panel. In that case, the machine should not be welding for 10-15 minutes to cool down with the fanrunning. When operating the machine again, the welding output current or the duty cycle should be reduced.

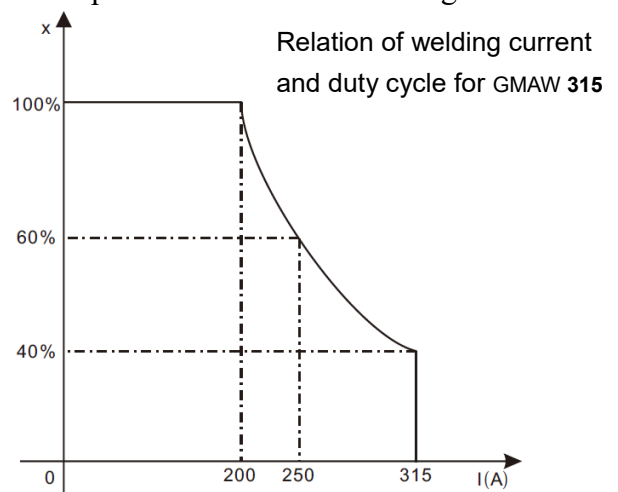

§3.3 Equipment Connection

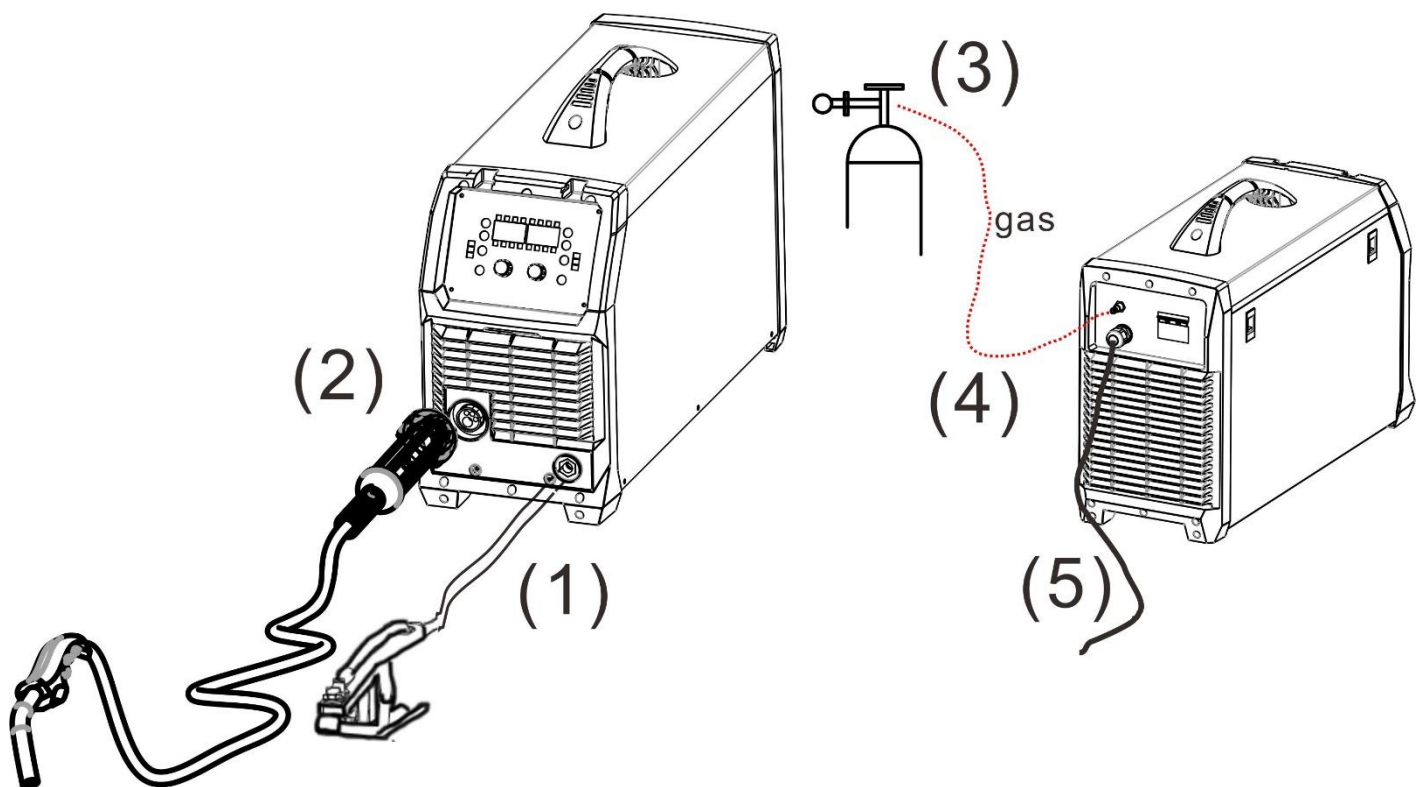

(1) Insert the earth cable plug into the negative socket on the front of the machine and tighten it.

(2) Plug the welding torch into the MIG torch connection socket on the front panel and tighten it.

IMPORTANT : When connecting the torch be sure to tighten the connection. A loose connection can result in the connector arcing and damaging the machine and gun connector.

(3) Connect the gas regulator to the Gas Cylinder and connect the gas line to the Gas Regulator.

Check for Leaks!

(4) Connect the gas line to gas connector on the rear panel. **Check for Leaks!**

(5) Connect the power cable of welding machine with the output switch in electric box on site.

OVERVIEW

§3.4 Maintenance of MIG Gun mechanism

§3.4.1 Dissection graphics for the MIG GUN

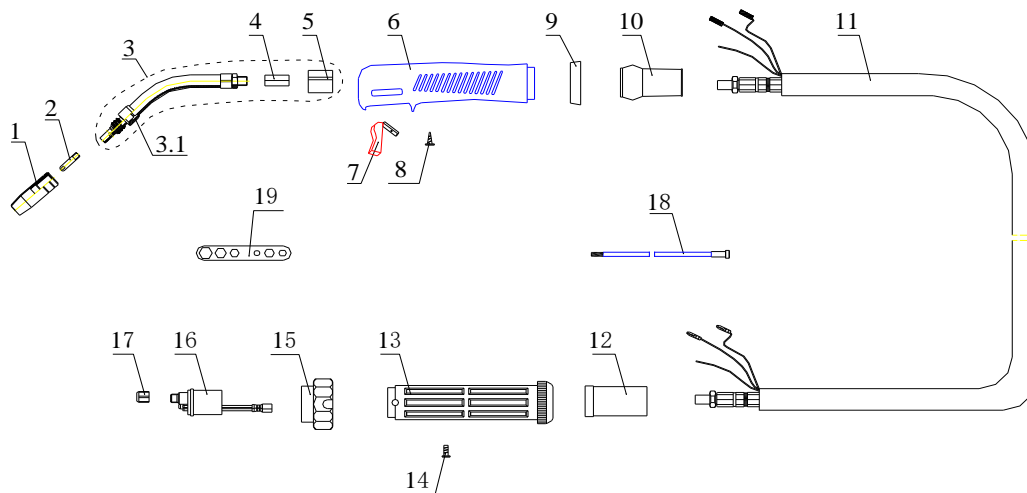

§3.4.2 Parts list for the MIG GUN

NO.	Description	QTY.	Remark
1	Tip D.12 14-15AK	1	
2	Electric nozzle 0.8/M6*25	1	
3	15AK Goose gun neck (Hexangular adapter and Plastic adapter)	1	
3.1	15AK Goose gun	1	
4	Hexangular adapter	1	
5	Plastic adapter	1	
6	MIG blue handle	1	
7	Torch Switch 21.8mm	1	
8	Screw D.3*10	3	
9	Handle locking ring	1	
10	Cable fixing joint 15AK	1	
11	Coaxial cable team /16mmq/3m	1	
12	Cable thimble 12-16-25 MMQ	1	
13	CO ₂ Euro-rear thimble	1	
14	Screw M4*6 UNI 6107	1	
15	Torch locknut /plastic screw thread	1	
16	Euro-main socket/flexibility pin	1	
17	Feeding pipe locknut	1	
18	Insulating feed pipe 0.6-0.8 3m, Blue	1	
19	Spanner for the electric nozzle	1	

OVERVIEW

§3.4.3 the operation for the MIG GUN

1. Service the wire feed mechanism at least every time the reel is changed.

- Check the wear of the feed roll groove and change the feed roll when necessary.
- Clean the welding gun wire guide with compressed air.

2. Cleaning the wire guide

Pressure of the feed rolls remove metal dust from the filler wire's surface which then finds its way to the wire guide. If the wire guide is not cleaned, it gradually clogs up and causes wire feed malfunctions. Clean the wire guide in the following manner:

Remove the welding gun's gas nozzle, contact tip and contact tip's adapter.

With a pneumatic pistol, blow compressed air through the wire guide.

Blow the wire feed mechanism and reel housing clean with compressed air.

Reattach the welding gun's parts. Tighten the contact tip and contact tip's adapter to spanner tightness.

3. Changing the wire guide

If the wire guide is too worn or totally clogged, change it to a new one according to the following instructions.

Open the mounting nut of the wire guide which exposes the end of the wire guide.

Straighten the welding gun's cable and withdraw the wire guide from the gun.

Push a new wire guide in to the gun. Make sure that the wire guide enters all the way into the contact tip's adapter and that there is an O-ring at the machine-end of the guide.

Tighten the wire guide in place with the mounting nut.

Cut the wire guide 2mm from the mounting nut and file the sharp edges of the cut round.

Reattach the gun in place and tighten the parts to spanner tightness.

Threading the filler wire

Threading the filler wire as the follow steps:

Open the reel housing by pressing on the opening button and install the wire reel in such a way that it rotates counter clockwise. You can use either a diameter 200mm or 100mm wire reel in the machine.

Attach the reel with a reel lock.

Unfasten the wire end from the reel, but hold on it all the time.

OVERVIEW

Straighten the wire end for approximately 20 cm and cut the wire in the straightened location.

Open the pressure control level which then opens the feed gear.

Thread the wire through the wire's rear guide to the gun's wire guide.

Close the feed gear and fasten it with the pressure control lever. Make sure that the wire runs in the feed roll groove.

Adjust the compression pressure with the pressure control lever no higher than to the middle of the scale. If the pressure is too high, it removes metal fragments from the wire surface and may damage the wire. On the other hand, if the pressure is too low, the feed gear slips and the wire does not run smoothly.

Press the welding gun trigger and wait for the wire to come out.

Close the reel housing cover.

Note: When driving the wire into the gun, do not point the gun at yourself or others.

§4 Operation

§4.1 Layout for the front and rear panel

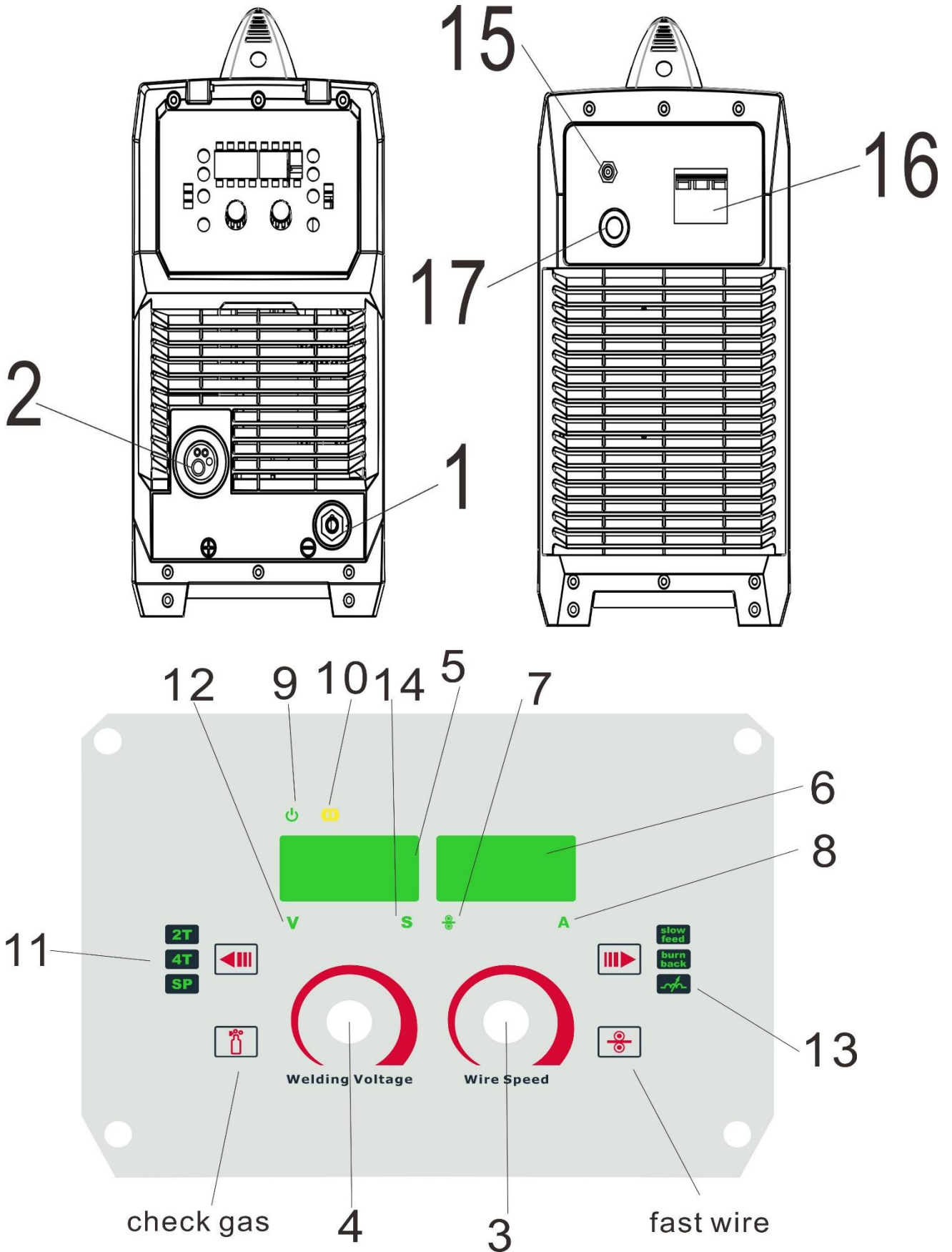

OVERVIEW

1. Output cathode
2. MIG GUN Connect.
3. Welding current/wire speed knob: Set the welding current/wire speed.
4. Welding volt knob: Set the welding volt
5. Voltage display: Welding voltage display when machine is working, Set voltage display when MIG mode before welding. Unit: V.
6. Current display: Welding Current display when machine is working, Set current display before welding. Unit: A.
7. Wire speed LED: You can use current setting knob to set the wire speed when the wire speed LED is on.
8. Current LED: When the current LED is on, it display the actual output welding current.
9. Power Led: Power led is lighted when open the machine.
10. Alarm Led: When the welder is over voltage, less voltage, over current or over heated, the alarm pilot lamp will be on.
11. Choose welding mode switch: 2T welding mode/ 4T welding mode/spot welding mode.
12. Voltage parameters LED
13. Wave control knob: Controls arc characteristics, Determines the rate at which the amperage rises when a short circuit is produced.
14. Second light
15. Shield gas input joint: To connect one head of the gas hose while the other head of which is connected to argon gas cylinder.
16. On/off switch: Control the power supply on and off.
17. Power source input: To connect power source.

OVERVIEW

§4.2 Wire Feeder of welding machine

1. Spool holder.
2. Wire feed motor.

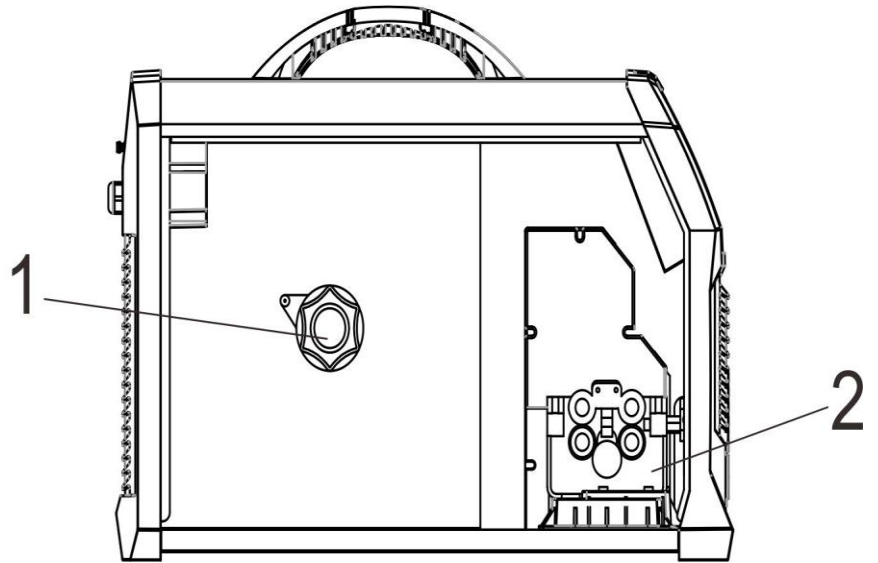

§4.3 Welding operation

- (1) Place the Wire Spool onto the Spool Holder. Snip the wire from the spool being sure to hold the wire to prevent rapid uncoiling. Feed the wire into the wire feeder inlet guide tube through to the drive roller.
- (2) Carefully feed the wire over the drive roller into the outlet guide tube, feed through about 150mm into the torch receptacle. Check that the drive roller size is compatible with the wire diameter, replace the roller if necessary.
- (3) Align the wire into the groove of the drive roller and close down the top roller making sure the wire is in the groove of the bottom drive roller, lock the pressure arm into place. Apply a medium amount of pressure to the drive roller.
- (4) Remove the gas nozzle and contact tip from the torch neck.
- (5) Press and hold the manual wire button to feed the wire through to the torch neck, release the manual wire key when the wire exits the torch neck.
- (6) Fit the correct sized contact tip and feed the wire through it, screw the contact tip into the tip holder of the torch head and nip it up tightly.
- (7) Fit the gas nozzle to the torch head.
- (8) Carefully open the gas cylinder valve and set the required gas flow rate.
- (9) Select 2T/4T trigger function.
- (10) Set the required welding parameters to suit the material thickness being welded, it will show on the digital meter .

OVERVIEW

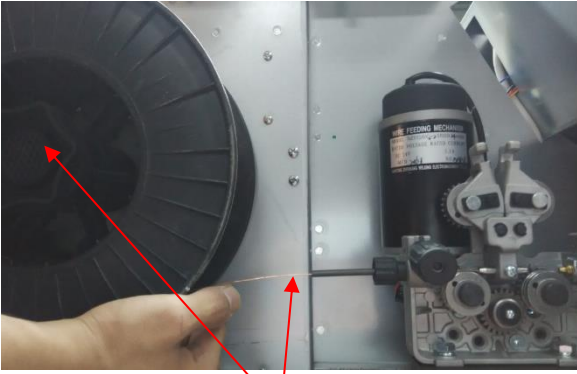

(1) Place wire onto spool holder - (spool retaining nut is left hand thread) Feed the wire through the

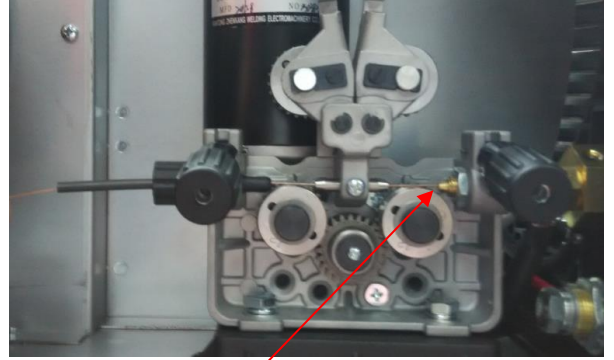

(2) Feed wire over the drive roller into the outlet guide tube, Push the wire through approx 150mm.

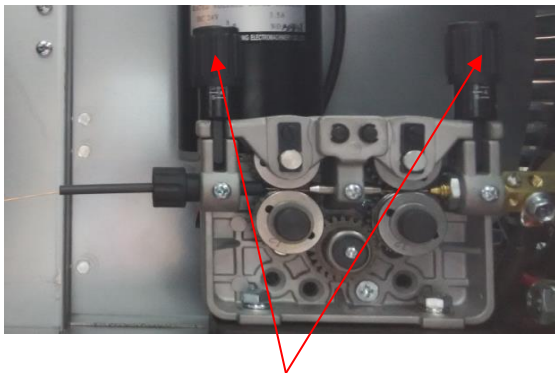

(3) Close down the top roller bracket and clip the pressure arm into place with a medium amount of pressure applied.

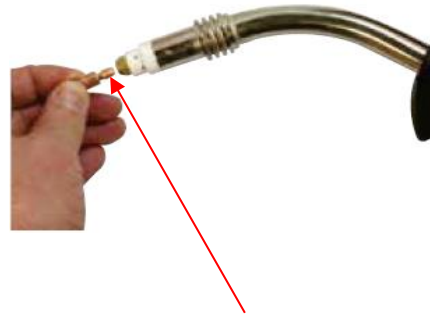

(4) Remove the gas nozzle and contact tip from the front end of the mig torch.

OVERVIEW

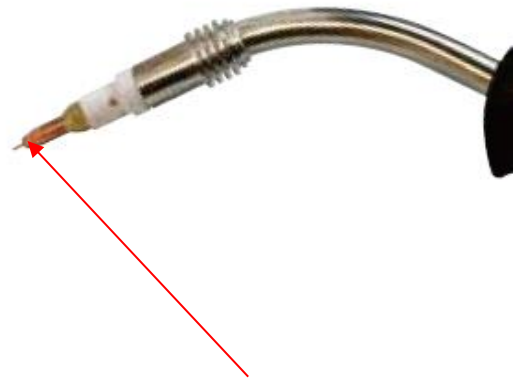
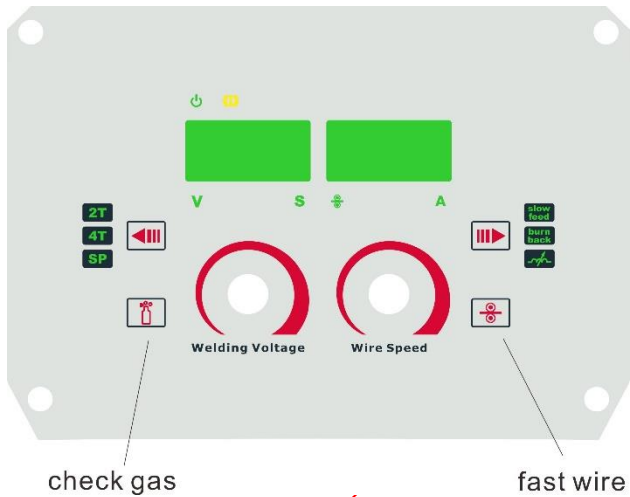

(5) Press and hold the manual wire switch (up) to feed the wire down the torch cable through to the torch head.

(6) Fit the correct size contact tip over the wire and fasten tightly into the tip holder.



(7) Fit the gas nozzle to the torch head.

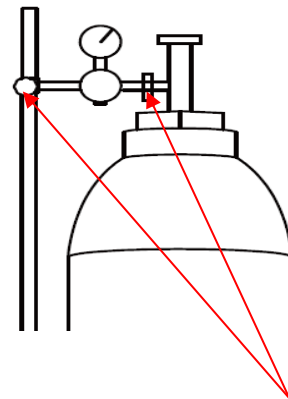

(8) Carefully open the gas cylinder valve and set the required gas flow rate.

OVERVIEW

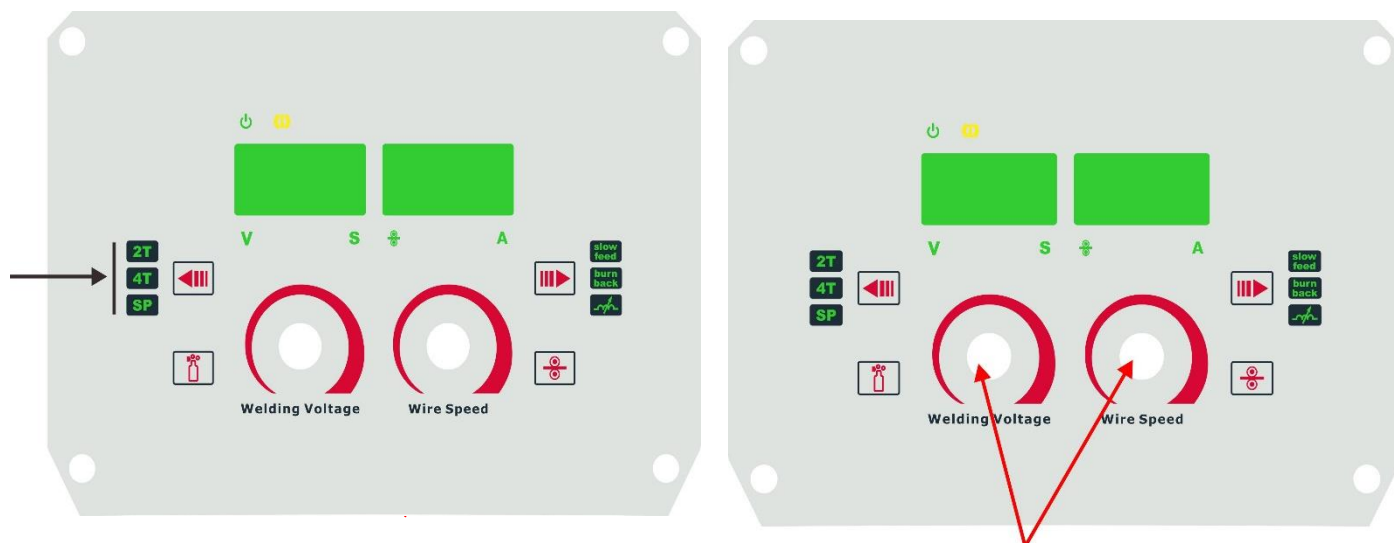

(9) Select torch switch mode 2T/ 4T

(10) Select the required welding parameters using the knobs.

§4.3.1 Wire Feed Roller Selection

The importance of smooth consistent wire feeding during MIG welding cannot be emphasized enough. Simply put the smoother the wire feed then the better the welding will be.

Feed rollers or drive rollers are used to feed the wire mechanically along the length of the welding gun. Feed rollers are designed to be used for certain types of welding wire and they have different types of grooves machined in them to accommodate the different types of wire. The wire is held in the groove by the top roller of the wire drive unit and is referred to as the pressure roller, pressure is applied by a tension arm that can be adjusted to increase or decrease the pressure as required. The type of wire will determine how much pressure can be applied and what type of drive roller is best suited to obtain optimum wire feed.

Solid Hard Wire - like Steel, Stainless Steel require a drive roller with a V shape groove for optimum grip and drive capability. Solid wires can have more tension applied to the wire from the top pressure roller that holds the wire in the groove and the V shape groove is more suited for this. Solid wires are more forgiving to feed due to their higher cross sectional column strength, they are stiffer and don't bend so easy.

Soft Wire - like Aluminium requires a U shape groove. Aluminium wire has a lot less column strength, can bend easily and is therefore more difficult to feed. Soft wires can easily buckle at the

OVERVIEW

wire feeder where the wire is fed into inlet guide tube of the torch. The U-shaped roller offers more surface area grip and traction to help feed the softer wire. Softer wires also require less tension from the top pressure roller to avoid deforming the shape of the wire, too much tension will push the wire out of shape and cause it to catch in the contact tip.

Flux Core / Gasless Wire - these wires are made up of a thin metal sheath that has flux and metal compounds layered onto it and then rolled into a cylinder to form the finished wire. The wire cannot take too much pressure from the top roller as it can be crushed and deformed if too much pressure is applied. A knurled drive roller has been developed and it has small serrations in the groove, the serrations grip the wire and assist to drive it without too much pressure from the top roller. The downside to the knurled wire feed roller on flux cored wire is it will slowly over time bit by bit eat away at the surface of the welding wire, and these small pieces will eventually go down into the liner. This will cause clogging in the liner and added friction that will lead to welding wire feed problems. A U groove wire can also be used for flux core wire without the wire particles coming off the wire surface. However it is considered that the knurled roller will give a more positive feed of flux core wire without any deformation of the wire shape.

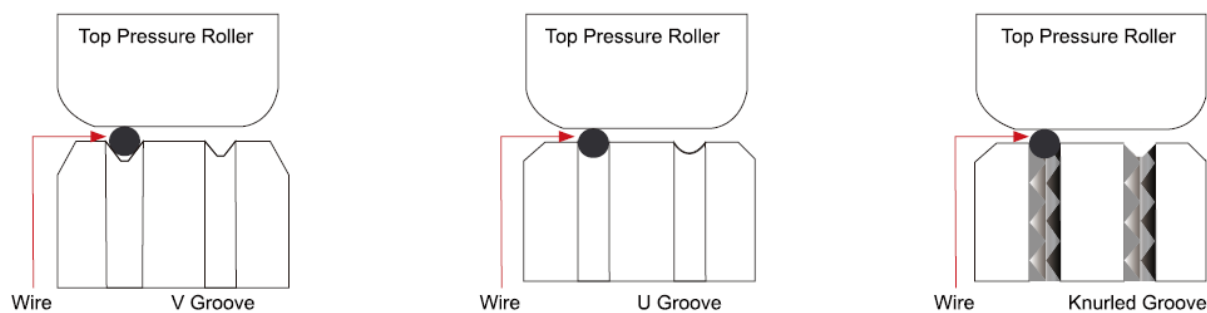

§4.3.2 Wire Installation and Set Up Guide

Again the importance of smooth consistent wire feeding during MIG welding cannot be emphasized enough. The correct installation of the wire spool and the wire into the wire feed unit is critical to achieving an even and consistent wire feed. A high percentage of faults with mig welders emanate from poor set up of the wire into the wire feeder. The guide below will assist in the correct setup of

OVERVIEW

your wire feeder.



(1) Remove the spool retaining nut.



(2) Note the tension spring adjuster and spool locating pin.

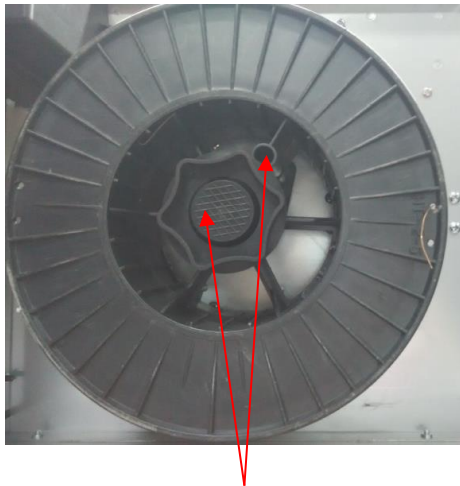

(3) Fit the wire spool onto the spool holder fitting the locating pin into the location hole on the spool. Replace the spool retaining nut tightly.

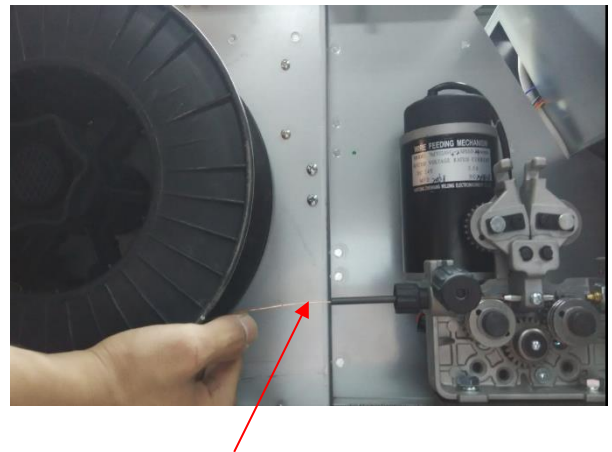

(4) Snip the wire carefully, be sure to hold the wire to prevent the spool uncoiling. Carefully feed the wire into the inlet guide tube of the wire feed unit.

OVERVIEW

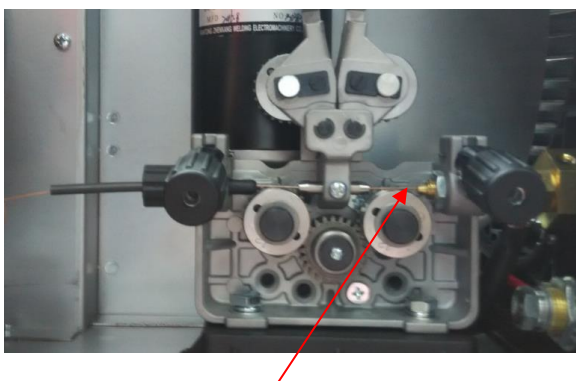

(5) Feed the wire through the drive roller and into the outlet guide tube of the wire feeder.

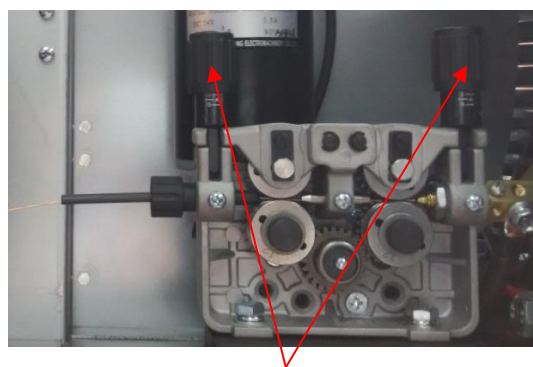

(6) Lock down the top pressure roller and apply a medium amount of pressure using the tension adjustment knob.



(7) Check that the wire passes through the centre of the outlet guide tube without touching the sides. Loosen the locking screw and then loosen the outlet guide tube retaining nut too make adjustment if required. Carefully retighten the locking nut and screw to hold the new position.



(8) A simple check for the correct drive tension is to bend the end of the wire over hold it about 100mm from your hand and let it run into your hand, it should coil round in your hand without stopping and slipping at the drive rollers, increase the tension if it slips.

OVERVIEW

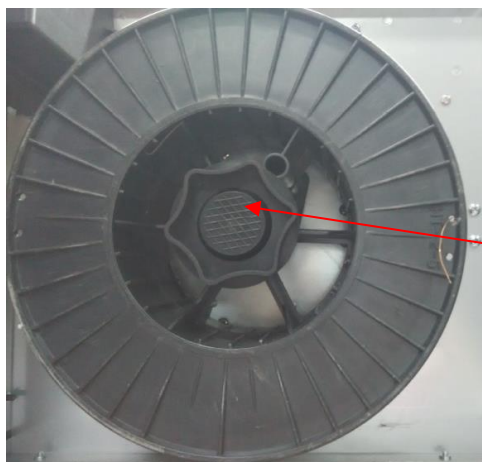

(9) The weight and speed of the wire spool turning creates an inertia that can cause the spool to run on and the wire loop over the side of the spool and tangle. if this happens increase the pressure on the tension spring inside the spool holder assembly using the tension adjustment screw.

§4.3.3 MIG Torch Liner Installation

- (1) Lay the torch out straight on the ground and remove the front end parts.
- (2) Remove the liner retaining nut.
- (3) Carefully pull the liner out of the torch cable assembly.
- (4) Select the correct new liner and carefully unravel avoiding putting any kinks in the liner, if you kink the liner it will make it no good and will require replacement.
- (5) Carefully and slowly feed the liner in short forward movements down the cable assembly all the way through and out the torch neck end. Avoid kinking the liner, kinking liner it will make it no good and require replacement.
- (6) Fit the liner retaining nut and screw down only 1/2 way .
- (7) Leaving the torch straight snip the liner approximately 3mm past the end of the torch neck .
- (8) Place the tip holder over the end of the liner and screw into the torch neck nipping it up tight.
- (9) Screw down the liner nut the remaining 1/2 and nip it up tight. This method compresses the liner inside the torch cable assembly preventing it moving during use and ensures good wire feed.

OVERVIEW

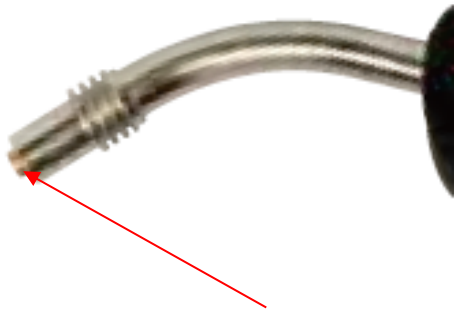

(1) Remove mig torch front end parts.



(2) Remove the liner retaining nut.



(3) Carefully pull out and completely remove the liner.

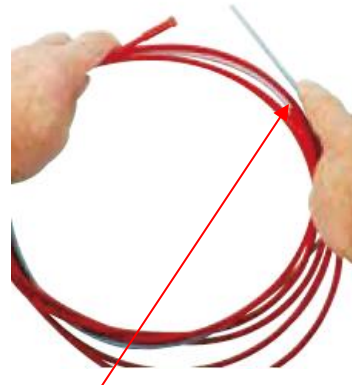

(4) Carefully unravel the new liner



(5) Carefully feed in the new liner down the torch lead all the way to exit the torch neck.



(6) Fit the liner retaining nut and screw only 1/2 way down.

OVERVIEW

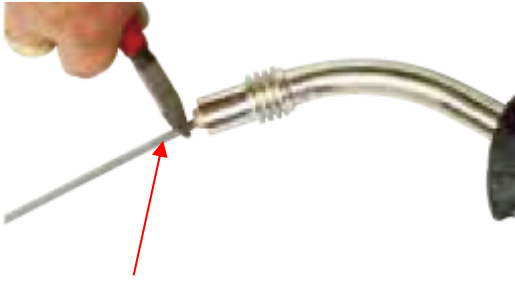

(7) Snip the liner off 3mm past the end of the torch neck.

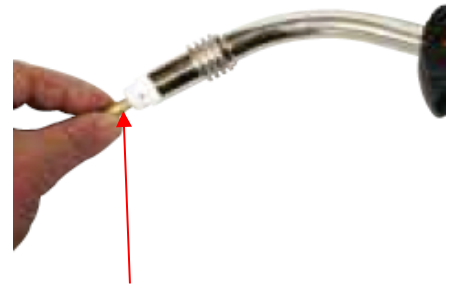

(8) Replace the front end parts.



(9) Fully screw down the liner retaining nut and

§4.3.4 MIG Torch Liner Types and Information

MIG Torch Liners

The liner is both one of the simplest and most important components of a MIG gun. Its sole purpose is to guide the welding wire from the wire feeder, through the gun cable and up to the contact tip.

Steel Liners

Most MIG gun liners are made from coiled steel wire also known as piano wire, which provides the liner with good rigidity and flexibility and allows it to guide the welding wire smoothly through the welding cable as it bends and flex during operational use. Steel liners are primarily used for feeding of solid steel wires, other wires such as Aluminium, Silicon Bronze etc will perform better using a teflon or Polyamide line. The internal diameter of the liner is important and relative to the wire diameter being used and will assist in smooth feeding and prevention of the wire kinking and birdnesting at the drive rollers. Also bending the cable too tightly during welding increases the friction between the liner and the welding wire making it more difficult to push the wire through the liner resulting in poor wire feeding, premature liner wear and birdnesting. Dust, grime and metal particles

OVERVIEW

can accumulate inside the liner over time and cause friction and blockages, it is recommended to periodically blow out the liner with compressed air. Small diameter welding wires, 0.6mm through 1.0mm have relatively low columnar strength, and if matched with an oversized liner, can cause the wire to wander or drift within the liner. This in turn leads to poor wire feeding and premature liner failure due to excessive wear. By contrast, larger diameter welding wires, 1.2mm through 2.4mm have much higher columnar strength but it is important to make sure the liner has enough internal diameter clearance. Most manufacturers will produce liners sized to match wire diameters and length of welding torch cable and most are colour coded to suit.



Teflon and Polyamide (PA) Liners

Teflon liners are well suited for feeding soft wires with poor column strength like aluminium wires. The interiors of these liners are smooth and provide stable feedability, especially on small diameter welding wire. Teflon can be good for higher heat applications that utilize water-cooled torches and brass neck liners. Teflon has good abrasion resistance characteristics and can be used with a variety of wire types such as silicon bronze, stainless steel as well as aluminium. A note of caution to carefully inspect the end of the welding wire prior to feeding it down the liner. Sharp edges and burrs can score the inside of the liner and lead to blockages and accelerated wear. Polyamide Liners (PA) are made of carbon infused nylon and are ideal for softer aluminum, copper alloy welding wires and push pull torch applications. These liners are generally fitted with a floating collet to allow the liner to be inserted all the way to the feed rollers.

OVERVIEW

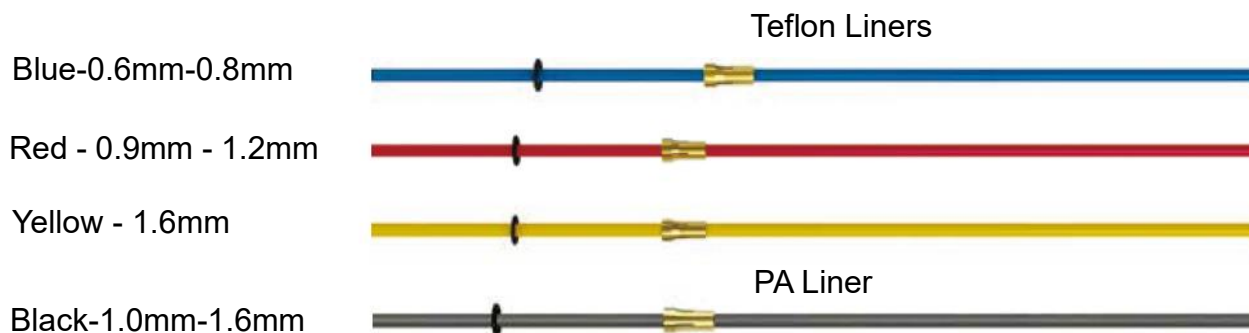

Copper - Brass Neck Liners

For high heat applications fitting brass or copper wound jumper or neck liner on the end of the liner at the neck end will increase the working temperature of the liner as well as improve the electrical conductivity of the welding power transfer to the wire.



§4.3.5 Torch & Wire Feed Set Up for Aluminium Wire

- (1) Lay the torch out straight on the ground and remove the front end parts
- (2) Remove the liner retaining nut.
- (3) Carefully pull the liner out of the torch cable assembly.
- (4) Select a PA or liner and carefully unravel avoiding putting any kinks in the liner.
- (5) Carefully and slowly feed the liner in short forward movements down the cable assembly all the way through and out the torch neck end. Avoid kinking the liner, kinking the liner will ruin it and require replacement.
- (6) Fit the liner retaining nut together with the liner o-ring, Push the liner firmly into the torch lead and tighten the liner retaining nut.
- (7) Leave the liner extending out the end of the torch neck end by 3mm.
- (8) Place the tip holder over the end of the liner and screw into the torch neck nipping it up tight.
- (9) Connect the torch to the machine tighten and secure the torch euro connector to the machine euro connection.

OVERVIEW

- (10) Install a U groove drive roller of the correct size to match the wire diameter being used.
- (11) Place aluminium wire onto spool holder. Feed the wire through the inlet guide tube on to the drive roller.
- (12) Press and hold the manual wire button to feed the wire down the torch cable through to the torch head.
- (13) Fit an Aluminium contact tip of the correct size to match the wire diameter being used
- (14) Fit the remaining front end parts to the torch neck ready for welding.

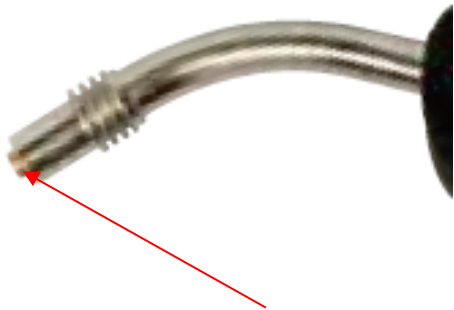

(1) Remove mig torch front end parts.



(2) Remove the liner retaining nut.



(3) Carefully pull out and completely remove the liner.

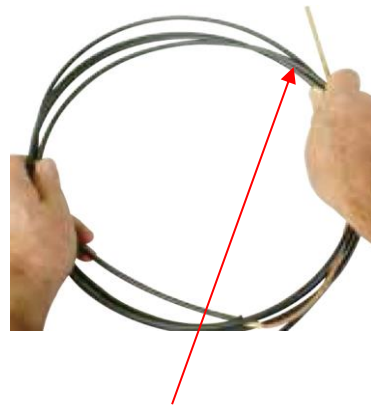

(4) Carefully unravel the new liner.

OVERVIEW



(5) Carefully feed in the new liner in short forward movements down the torch lead all the way to exit the torch neck. Be care-full not to kink the liner.

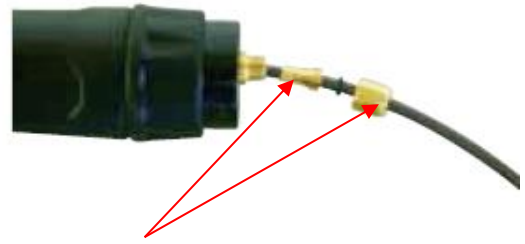

(6) Fit the liner collet, liner O-ring and liner retaining nut.



(6) Push the liner firmly into the torch lead and tighten the liner retaining nut.

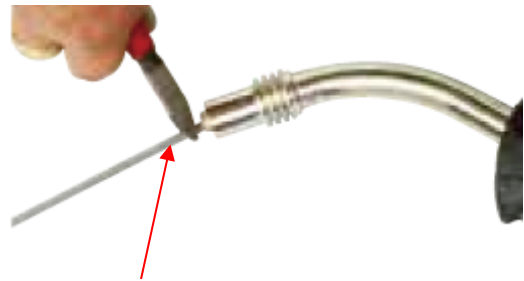

(7) Snip the liner off 3mm past the end of the torch neck.

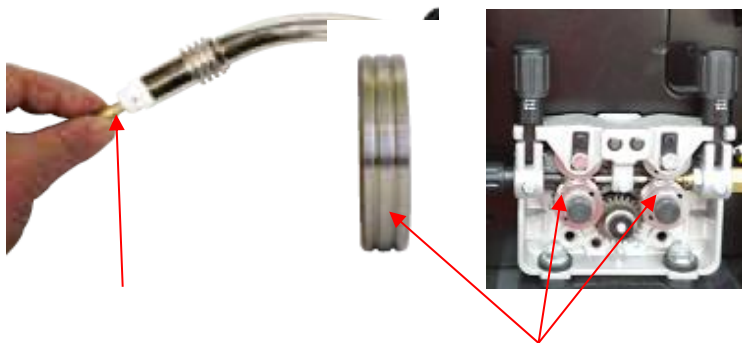

(8) Replace the front end parts.

(10) Install a U groove drive roller of the size for the diameter wire being used.

OVERVIEW



(11) Place aluminium wire onto spool holder. Feed the wire through the inlet guide tube on to the drive roller.

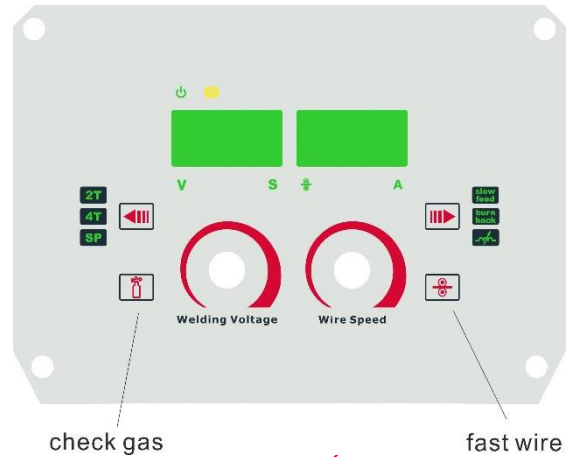

(12) Press and hold the manual wire button (right) to feed the wire down the torch cable through to the torch head.

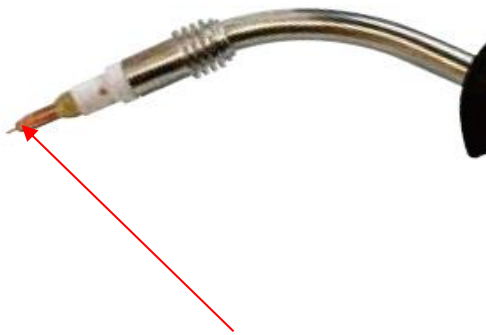

(13) Fit an Aluminium contact tip of the correct size to match the wire diameter being used.



(14) Fit the remaining front end parts to the torch neck ready for welding.

§4.3.6 MIG Welding

Definition of MIG Welding

MIG (metal inert gas) welding also known as GMAW (gas metal arc welding) or MAG (metal active gas welding), is a semi-automatic or automatic arc welding process in which a continuous and consumable wire electrode and a shielding gas are fed through a welding gun. A constant voltage, direct current power source is most commonly used with MIG welding. There are four primary methods of metal transfer in MIG welding, called short circuit (also known as dip transfer) globular transfer, spray transfer and pulsed-spray, each of which has distinct properties and corresponding

OVERVIEW

advantages and limitations. To perform MIG welding, the basic necessary equipment is a welding gun, a wire feed unit, a welding power supply, an electrode wire, and a shielding gas supply. Short circuit transfer is the most common used method whereby the wire electrode is fed continuously down the welding torch through to and exiting the contact tip. The wire touches the work piece and causes a short circuit the wire heats up and begins to form a molten bead, the bead separates from the end of the wire and forms a droplet that is transferred into the weld pool. This process is repeated about 100 times per second, making the arc appear constant to the human eye.

Short Circuit Transfer - Short circuit transfer is the most common used method whereby the wire electrode is fed continuously down the welding torch through to and exiting the contact tip. The wire touches the work piece and causes a short circuit the wire heats up and begins to form a molten bead, the bead separates from the end of the wire and forms a droplet that is transferred into the weld pool. This process is repeated about 100 times per second, making the arc appear constant to the human eye.

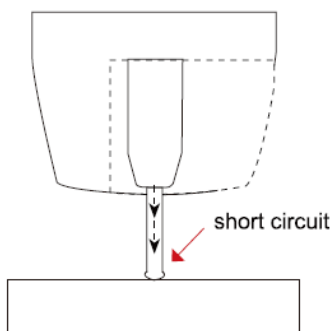

The wire approaches the work piece and touches the work creating a short circuit between the wire and the base metal, because there is no space between the wire and the base metal there is no arc and current flows through the wire.

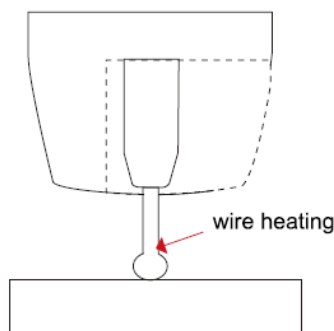

The wire cannot support all the current flow, resistance builds up and the wire becomes hot and weak and begins to melt.

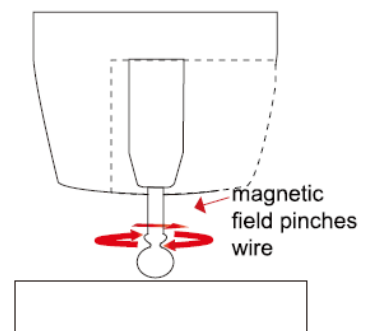

The current flow creates a magnetic field that begins to pinch the melting wire forming it into droplet.

OVERVIEW

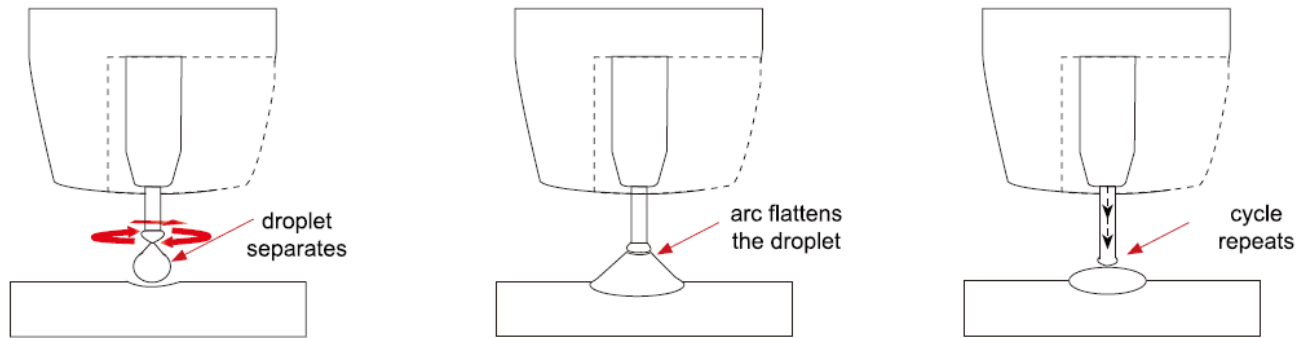

The pinch causes the forming droplet to separate and fall towards the now creating weld pool.

An arc is created at the separation of the droplet and the heat and force of the arc flattens out the droplet into the weld pool. The heat of the arc melts the end of the wire slightly as it feeds towards the base metal.

The wire feed speed overcomes the heat of the arc and the wire again approaches the work to short circuit and repeat the cycle.

Basic MIG Welding

Good weld quality and weld profile depends on gun angle, direction of travel, electrode extension (stick out), travel speed, thickness of base metal, wire feed speed and arc voltage. To follow are some basic guides to assist with your setup.

Gun Position - Travel Direction, Work Angle: Gun position or technique usually refers to how the wire is directed at the base metal, the angle and travel direction chosen. Travel speed and work angle will determine the characteristic of the weld bead profile and degree of weld penetration

Push Technique - The wire is located at the leading edge of the weld pool and pushed towards the un-melted work surface. This technique offers a better view of the weld joint and direction of the wire into the weld joint. Push technique directs the heat away from the weld puddle allowing faster travel speeds providing a flatter weld profile with light penetration - useful for welding thin materials. The welds are wider and flatter allowing for minimal clean up / grinding time.

Perpendicular Technique - The wire is fed directly into the weld, this technique is used primarily for automated situations or when conditions make it necessary. The weld profile is generally higher and a deeper penetration is achieved.

OVERVIEW

Drag Technique - The gun and wire is dragged away from the weld bead. The arc and heat is concentrated on the weld pool, the base metal receives more heat, deeper melting, more penetration and the weld profile is higher with more build up.

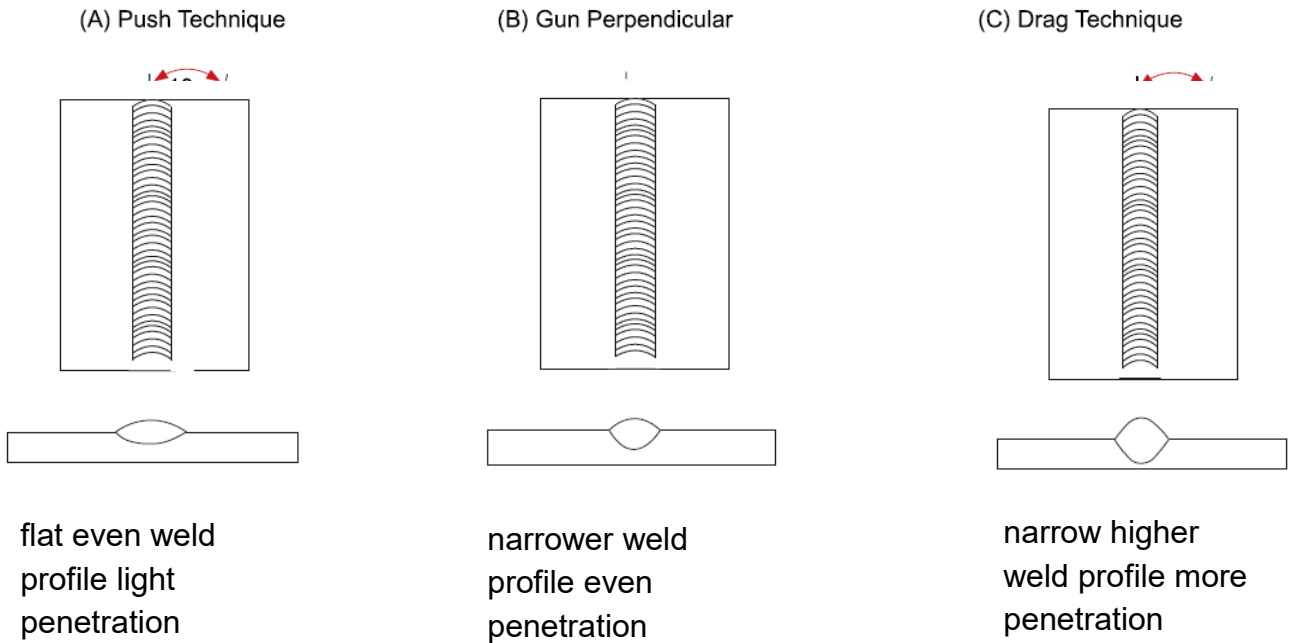

Travel Angle - Travel angle is the right to left angle relative to the direction of welding. A travel angle of 5° - 15° is ideal and produces a good level of control over the weld pool. A travel angle greater than 20° will give an unstable arc condition with poor weld metal transfer, less penetration, high levels of spatter, poor gas shield and poor quality finished weld.

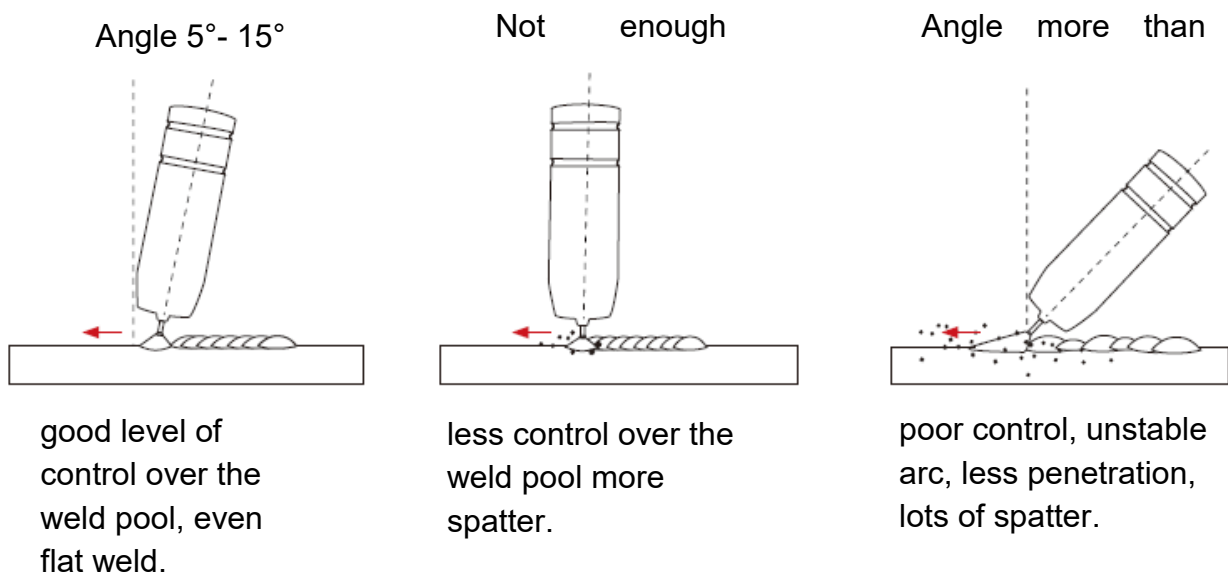

OVERVIEW

Angle to Work - The work angle is the forward back angle of the gun relative to the work piece. The correct work angle provides good bead shape, prevents undercut, uneven penetration, poor gas shield and poor quality finished weld.

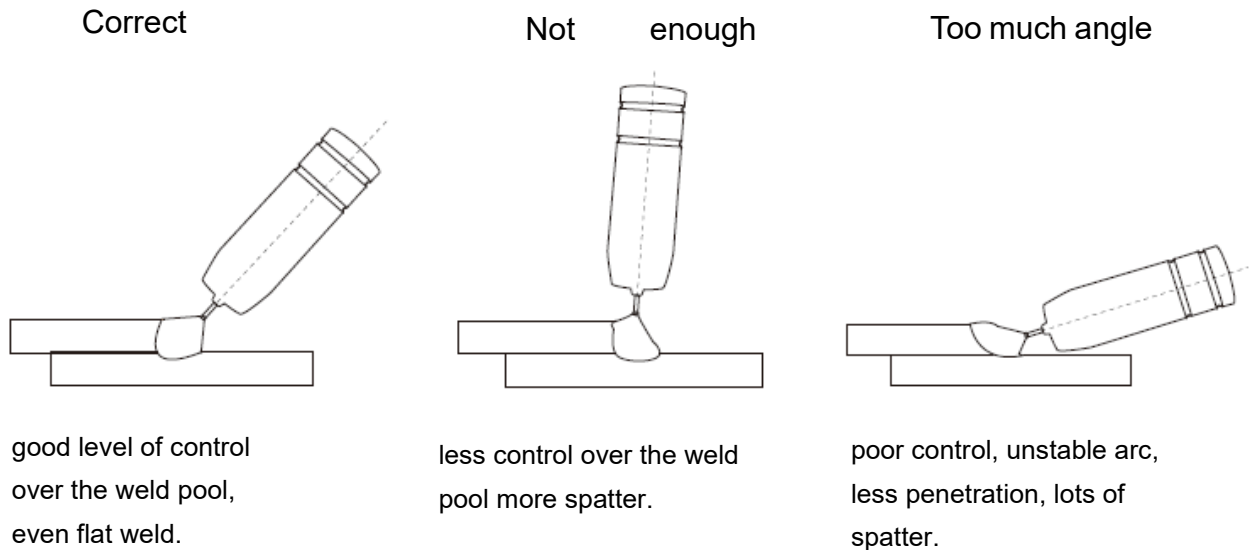

Stick Out- Stick out is the length of the unmelted wire protruding from the end of the contact tip. A constant even stick out of 5-10mm will produce a stable arc, and an even current flow providing good penetration and even fusion. Too short stick out will cause an unstable weld pool, produce spatter and over heat the contact tip. Too long stick out will cause an unstable arc, lack of penetration, lack of fusion and increase spatter.

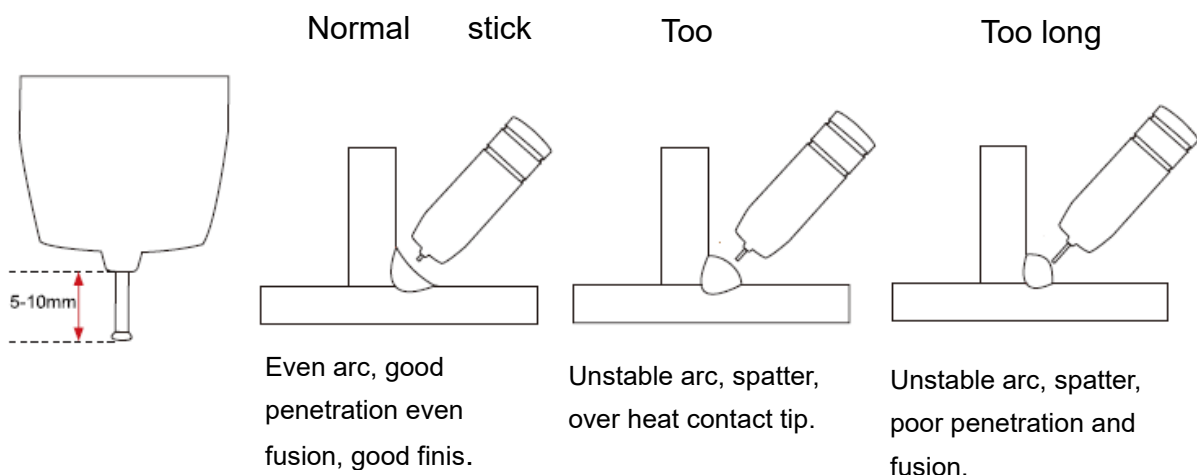

Travel Speed - Travel speed is the rate that the gun is moved along the weld joint and is usually measured in mm per minute. Travel speeds can vary depending on conditions and the welders skill

OVERVIEW

and is limited to the welders ability to control the weld pool. Push technique allows faster travel speeds than Drag technique. Gas flow must also correspond with the travel speed, increasing with faster travel speed and decreasing with slower speed. Travel speed needs to match the amperage and will decrease as the material thickness and amperage increase.

Too Fast Travel Speed - A too fast travel speed produces too little heat per mm of travel resulting in less penetration and reduced weld fusion, the weld bead solidifies very quickly trapping gases inside the weld metal causing porosity. Undercutting of the base metal can also occur and an unfilled groove in the base metal is created when the travel speed is too fast to allow molten metal to flow into the weld crater created by the arc heat.

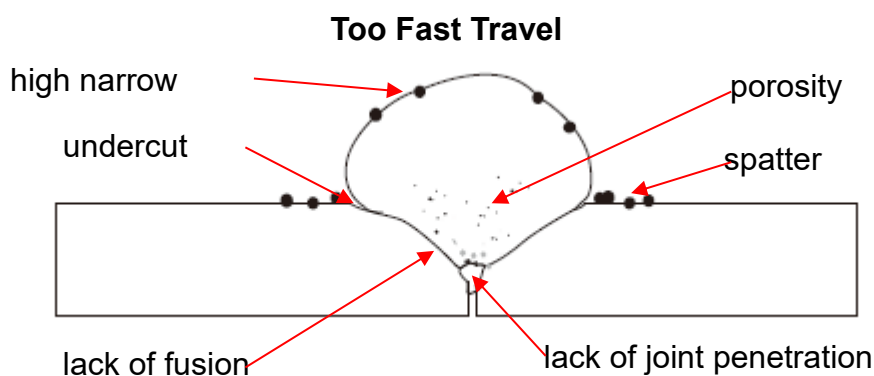

Too Slow Travel Speed - A too slow travel speed produces a large weld with lack of penetration and fusion. The energy from the arc dwells on top of the weld pool rather than penetrating the base metal. This produces a wider weld bead with more deposited weld metal per mm than is required resulting in a weld deposit of poor quality.

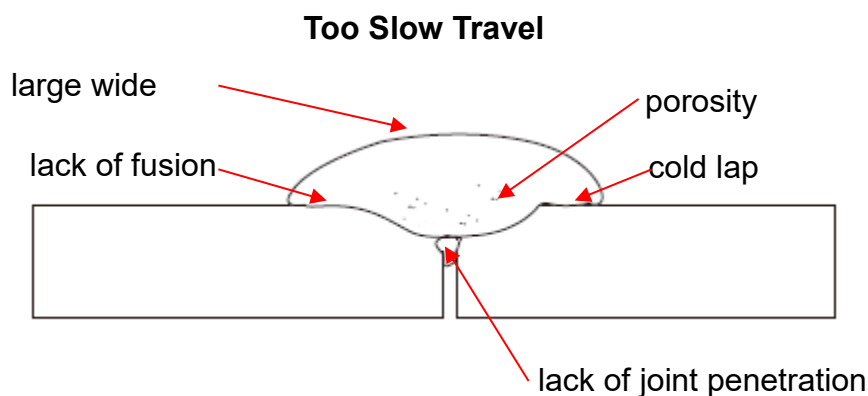

OVERVIEW

Correct Travel Speed - The correct travel speed keeps the arc at the leading edge of the weld pool allowing the base metal to melt sufficiently to create good penetration, fusion and wetting out of the weld pool producing a weld deposit of good quality.

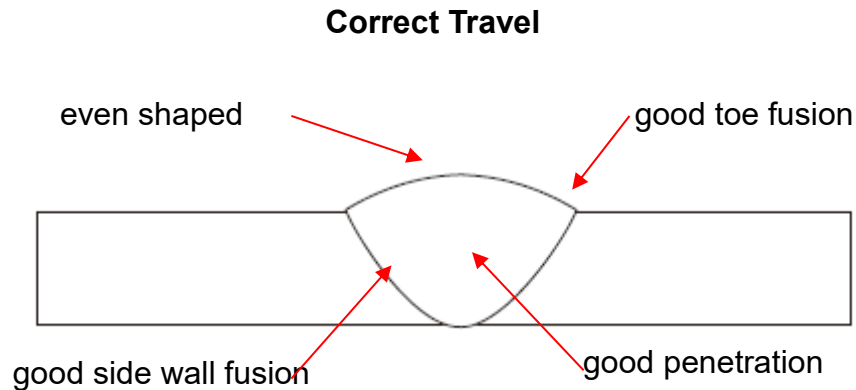

Wire types and sizes - Use the correct wire type for the base metal being welded. Use stainless steel wire for stainless steel, aluminium wires for aluminium and steel wires for steel.

Use a smaller diameter wire for thin base metals. For thicker materials use a larger wire diameter and larger machine, check the recommended welding capability of your machine. As a guide refer to the “Welding Wire Thickness Chart” below.

WELDING WIRE DIAMETER CHART					
MATERIAL THICKNESS	RECOMMENDED WIRE DIAMETERS				
	0.8	0.9	1.0	1.2	1.6
0.8mm					
0.9mm					
1.0mm					
1.2mm					
1.6mm					
2.0mm					
2.5mm					
3.0mm					
4.0mm					
5.0mm					
6.0mm					
8.0mm					
10mm					
14mm					
18mm					

OVERVIEW

22mm					
For material thickness of 5.0mm and greater, multi-pass runs or a beveled joint design may be required depending on the amperage capability of your machine.					

Gas selection - The purpose of the gas in the MIG process is to protect / shield the wire, the arc and the molten weld metal from the atmosphere. Most metals when heated to a molten state will react with the air in the atmosphere, without the protection of the shielding gas the weld produced would contain defects like porosity, lack of fusion and slag inclusions. Additionally some of the gas becomes ionised (electrically charged) and helps the current flow smoothly.

The correct gas flow is also very important in protecting the welding zone from the atmosphere. Too low flow will give inadequate coverage and result in weld defects and unstable arc conditions. Too high flow can cause air to be drawn into the gas column and contaminate the weld zone.

Use the correct shielding gas. Co₂ is good for steel and offers good penetration characteristics, the weld profile is narrower and slightly more raised than the weld profile obtained from Argon Co₂ mixed gas. Argon Co₂ mix gas offers better weld ability for thin metals and has a wider range of setting tolerance on the machine. Argon 80% Co₂ 20% is a good all round mix suitable for most applications.

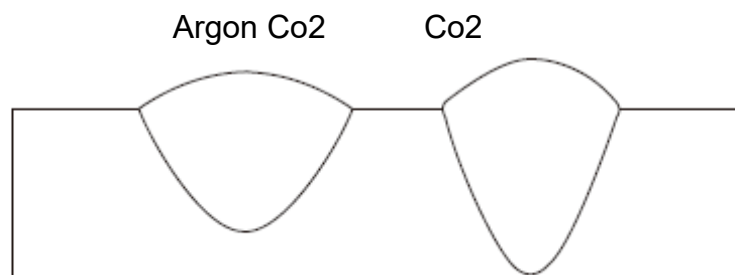

Penetration Pattern for Steel

§4.4 Welding parameters

Process reference for CO₂ butt welding of low carbon steel solid welding wire

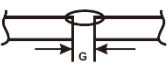
Butt-joint 	Material thickness (MM)	Root gap G (MM)	Wire diameter (MM)	Welding current (A)	Welding voltage (V)	Welding speed (CM/MIN)	Gas-flow rate (L/MIN)
	0.8	0	0.8	60-70	16-16.5	50-60	10
	1.0	0	0.8	75-85	17-17.5	50-60	10-15
	1.2	0	0.8	80-90	17-18	50-60	10-15
	2.0	0-0.5	1.0/1.2	110-120	19-19.5	45-50	10-15
	3.2	0-1.5	1.2	130-150	20-23	30-40	10-20
	4.5	0-1.5	1.2	150-180	21-23	30-35	10-20
	6	0	1.2	270-300	27-30	60-70	10-20
	6	1.2-1.5	1.2	230-260	24-26	40-50	15-20
	8	0-1.2	1.2	300-350	30-35	30-40	15-20
	8	0-0.8	1.6	380-420	37-38	40-50	15-20
12	0-1.2	1.6	420-480	38-41	50-60	15-20	

Process reference for CO₂ corner welding of low carbon steel solid welding wire

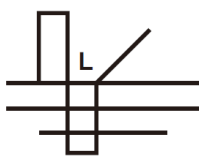
Corner joint 	Material thickness (MM)	Wire diameter (MM)	Welding current (A)	Welding voltage (V)	Welding speed (CM/MIN)	Gas-flow rate (L/MIN)
	1.0	0.8	70-80	17-18	50-60	10-15
	1.2	1.0	85-90	18-19	50-60	10-15
	1.6	1.0/1.2	100-110	18-19.5	50-60	10-15
	1.6	1.2	120-130	19-20	40-50	10-20
	2.0	1.0/1.2	115-125	19.5-20	50-60	10-15
	3.2	1.0/1.2	150-170	21-22	45-50	15-20
	3.2	1.2	200-250	24-26	45-60	10-20
	4.5	1.0/1.2	180-200	23-24	40-45	15-20
	4.5	1.2	200-250	24-26	40-50	15-20
	6	1.2	220-250	25-27	35-45	15-20
	6	1.2	270-300	28-31	60-70	15-20
	8	1.2	270-300	28-31	60-70	15-20
	8	1.2	260-300	26-32	25-35	15-20
	8	1.6	300-330	25-26	30-35	15-20
	12	1.2	260-300	26-32	25-35	15-20
	12	1.6	300-330	25-26	30-35	15-20
16	1.6	340-350	27-28	35-40	15-20	
19	1.6	360-370	27-28	30-35	15-20	

Low carbon steel, stainless steel pulse MAG welding process reference

Welding position	Material thickness (MM)	Wire diameter (MM)	Welding current (A)	Welding voltage (V)	Welding speed (CM/MIN)	Nozzle and workpiece spacing (MM)	Gas-flow rate (L/MIN)
	1.6	1.0	80-100	19-21	40-50	12-15	10-15

OVERVIEW

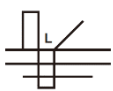
Butt-joint 	2.0	1.0	90-100	19-21	40-50	13-16	13-15
	3.2	1.2	150-170	22-25	40-50	14-17	15-17
	4.5	1.2	150-180	24-26	30-40	14-17	15-17
	6.0	1.2	270-300	28-31	60-70	17-22	18-22
	8.0	1.6	300-350	39-34	35-45	20-24	18-22
	10.0	1.6	330-380	30-36	35-45	20-24	18-22
Corner joint 	1.6	1.0	90-130	21-25	40-50	13-16	10-15
	2.0	1.0	100-150	22-26	35-45	13-16	13-15
	3.2	1.2	160-200	23-26	40-50	13-17	13-15
	4.5	1.2	200-240	24-28	45-55	15-20	15-17
	6.0	1.2	270-300	28-31	60-70	18-22	18-22
	8.0	1.6	280-320	27-31	45-60	18-22	18-22
	10.0	1.6	330-380	30-36	40-55	20-24	18-22

Welding process of aluminum alloy pulse MIG

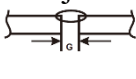
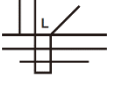
Welding position	Material thickness (MM)	Wire diameter (MM)	Welding current (A)	Welding voltage (V)	Welding speed (CM/MIN)	Nozzle and workpiece spacing (MM)	Gas-flow rate (L/MIN)
Butt-joint 	1.5	1.0	60-80	16-18	60-80	12-15	15-20
	2.0	1.0	70-80	17-18	40-50	15	15-20
	3.0	1.2	80-100	17-20	40-50	14-17	15-20
	4.0	1.2	90-120	18-21	40-50	14-17	15-20
	6.0	1.2	150-180	20-23	40-50	17-22	18-22
	4.0	1.2	160-210	22-25	60-90	15-20	19-20
	4.0	1.6	170-200	20-21	60-90	15-20	19-20
	6.0	1.2	200-230	24-27	40-50	17-22	20-24
	6.0	1.6	200-240	21-23	40-50	17-22	20-24
	8.0	1.6	240-270	24-27	45-55	17-22	20-24
	12.0	1.6	270-330	27-35	55-60	17-22	20-24
16.0	1.6	330-400	27-35	55-60	17-22	20-24	
Corner joint 	1.5	1.0	60-80	16-18	60-80	13-16	15-20
	2.0	1.0	100-150	22-26	35-45	13-16	15-20
	3.0	1.2	100-120	19-21	40-60	13-17	15-20
	4.0	1.2	120-150	20-22	50-70	15-20	15-20
	6.0	1.2	150-180	20-23	50-70	18-22	18-22
	4.0	1.2	180-210	21-24	35-50	18-22	16-18
	4.0	1.6	180-210	18-20	35-45	18-22	18-22
	6.0	1.2	220-250	24-25	50-60	18-22	16-24
	6.0	1.6	220-240	20-24	37-50	18-22	16-24
	8.0	1.6	250-300	25-26	60-65	18-22	16-24
	12.0	1.6	300-400	26-28	65-75	18-22	16-24

§4.5 Operation environment

- ▲ Height above sea level ≤ 1000 M
- ▲ Operation temperature range $-10 \sim +40^{\circ}\text{C}$
- ▲ Air relative humidity is below 90 % (20°C)
- ▲ Preferable site the machine some angles above the floor level, the maximum angle does not exceed 15°C .
- ▲ Protect the machine against heavy rain AND against direct sunshine.
- ▲ The content of dust, acid, corrosive gas in the surrounding air or substance cannot exceed normal standard.
- ▲ Take care that there is sufficient ventilation during welding. There must be at least 30cm free distance between the machine and wall.

§4.6 Operation Notices

- ▲ Read Section §1 carefully before starting to use this equipment.
- ▲ Connect the ground wire with the machine directly.
- ▲ Ensure that the input is three-phase: 50/60Hz, 380V $\pm 10\%$.
- ▲ Before operation, none concerned people should not be around the working area and especially children. Do not watch the arc in unprotected eyes.
- ▲ Ensure good ventilation of the machine to improve Duty Cycle.
- ▲ Turn off the engine when the operation finished for energy consumption efficiency.
- ▲ When power switch shuts off protectively because of failure. Don't restart it until problem is resolved. Otherwise, the range of problem will be extended.
- ▲ In case of problems, contact your local dealer if no authorized maintenance staff is available!

§5 Maintenance & Troubleshooting

§5.1 Maintenance

In order to guarantee safe and proper operation of welding machines, they must be maintained regularly. Let customers understand the maintenance procedure of welding machines. Enable customers to carry on simple examination and inspections. Do your best to reduce the fault rate and repair times of welding machines to lengthen service life of arc welding machine. Maintenance items in detail are in the following table.

- **Warning: For safety while maintaining the machine, please shut off the main input power and wait for 5 minutes, until capacitors voltage already drop to safe voltage 36V!**

Date	Maintenance items
Daily examination	<p>Observe that the knobs and switches in the front and at the back of arc welding machine are flexible and put correctly in place. If any knob has not been put correctly in place, please correct. If you can't correct or fix the knob, please replace immediately;</p> <p>If any switch is not flexible or it can't be put correctly in place, please replace immediately! Please get in touch with maintenance service department if there are no accessories.</p> <p>After turn-on power, watch/listen if the arc-welding machine has shaking, whistle calling or peculiar smell. If there is one of the above problems, find out the reason and clear it. If you can't find out the reason, please contact your local service repair station or distributor/Agent.</p> <p>Observe that the display value of LED is intact. If the display number is not intact, please replace the damaged LED. If it still doesn't work, please maintain or replace the display PCB.</p> <p>Observe that the min./max. Values on LED agree with the set value. If there is any difference and it has affected the normal welding results, please adjust it.</p> <p>Check whether the fan is damaged and whether it is normal to rotate or control. If the fan is damaged, please change immediately. If the fan does not rotate after the machine is overheated, observe if there is something blocking the blade. If it is blocked, please clear the problem. If the fan does not rotate after getting rid of the above problems, you can poke the blade by the rotation direction of fan. If the fan rotates normally, the start capacity should be replaced. If not, change the fan.</p> <p>Observe whether the fast connector is loose or overheated. If the arc-welding machine has the above problems, it should be fastened or changed.</p> <p>Observe whether the current output cable is damaged. If it is damaged, it should be insulated or changed.</p>

OVERVIEW

Monthly examination	Using the dry compressed air to clear the inside of arc welding machine. Especially for clearing up the dusts on radiator, main voltage transformer, inductors, IGBT modules, fast recover diodes, PCB's, etc. Check the screws and bolts in the machine. If any is loose, please screw it tight. If it is shaved, please replace. If it is rusty, please erase rust on all bolts to ensure it works well.
Quarter-yearly examination	Check whether the actual current accords with the displaying value. If they did not accord, they should be regulated. The actual welding current value can be measured by and adjusted by plier-type ampere meter.
Yearly examination	Measure the insulating impedance among the main circuit, PCB and case, if it below $1M\Omega$, insulation is thought to be damaged and need to change, and need to change or strengthen insulation.

§5.2 Troubleshooting

- Before the welding machines are dispatched from the factory, they have already been tested and calibrated accurately. **It is forbidden for anyone who is not authorized by our company to do any change to the equipment!**
- Maintenance course must be operated carefully. If any wire becomes flexible or is misplaced, it maybe potential danger to user!
- Only professional maintenance staff that is authorized by our company could overhaul the machine!
- **Be sure to shut off the Main Input Power before doing any repair work on the welding machine!**
- If there is any problem and there is no authorized professional maintenance personal on site, please contact local agent or the distributor!

If there are some simple troubles with the welding machine, you can consult the following Chart:

OVERVIEW

NO.	Troubles		Reasons	Solution
1	Close the breaker, but the power light isn't on		Breaker damaged	Change it
			Fuse damaged	Change it
			Input power damaged	Change it
2	After welding machine is over-heat, the fan doesn't work		Fan damaged	Change it
			The cable is loose	Screw the cable tight
3	Press the gun switch, no output shielded gas	No output gas when test gas	No gas in the gas cylinder	Change it
			Gas hose leaks gas	Change it
			Electromagnetic valve damaged	Change it
	Output gas when test gas	Control switch damaged	Repair the switch	
		Control circuit damaged	Check the PCB	
4	Wire-feeder doesn't work	Wire reel doesn't work	Motor damaged	Check and change it
			Control circuit damaged	Check the PCB
		Wire reel works	The press wheel is loosen or weld wire skids	Press it tightly again
			The wheel doesn't fit with the diameter of weld wire	Change the wheel
			Wire reel damaged	Change it
			Wire feed pipe is jammed	Repair or change it
			Tip is jammed because of splash	Repair or change it
5	No striking arc and no output voltage		Output cable is connected incorrectly or loosen	Screw it down or change it
			Control circuit damaged	Check the circuit
6	Welding stops, and alarm light is on		Machine has self-protection	Check over-voltage, over-current, over-temperature, lower-voltage and over-temperature, and solve it
7	Welding current is run away and can be not controlled		The potentiometer damaged	Check or change it
			The control circuit damaged	Check the circuit
8	The crater current can be not adjusted		The PCB damaged	Check it
9	No post-gas		The PCB damaged	Check it

§5.3 List of error code

Error Type	Error code	Description	Lamp status
Thermal relay	E01	Over-heating(1st thermal relay)	Yellow lamp(thermal protection) always on
	E02	Over-heating(2nd thermal relay)	Yellow lamp(thermal protection) always on
	E03	Over-heating(3rd thermal relay)	Yellow lamp(thermal protection) always on
	E04	Over-heating(4th thermal relay)	Yellow lamp(thermal protection) always on
	E09	Over-heating(Program in default)	Yellow lamp(thermal protection) always on
Welding machine	E10	Phase loss	Yellow lamp(thermal protection) always on
	E11	No water	Yellow lamp(lack water) always on
	E12	No gas	Red lamp always on
	E13	Under voltage	Yellow lamp(thermal protection) always on
	E14	Over voltage	Yellow lamp(thermal protection) always on
	E15	Over current	Yellow lamp(thermal protection) always on
	E16	Wire feeder over load	
Switch	E20	Button fault on operating panel when switch on the machine	Yellow lamp(thermal protection) always on
	E21	Other faults on operating panel when switch on the machine	Yellow lamp(thermal protection) always on
	E22	Torch fault when switch on the machine	Yellow lamp(thermal protection) always on
	E23	Torch fault during normal working process	Yellow lamp(thermal protection) always on
Accessory	E30	Cutting torch disconnection	Red lamp blink
	E31	Water cooler disconnection	Yellow lamp(lack water) always on
Communication	E40	Connection problem between wire feeder and power source	
	E41	Communication error	

§5.4 Electrical schematic drawing

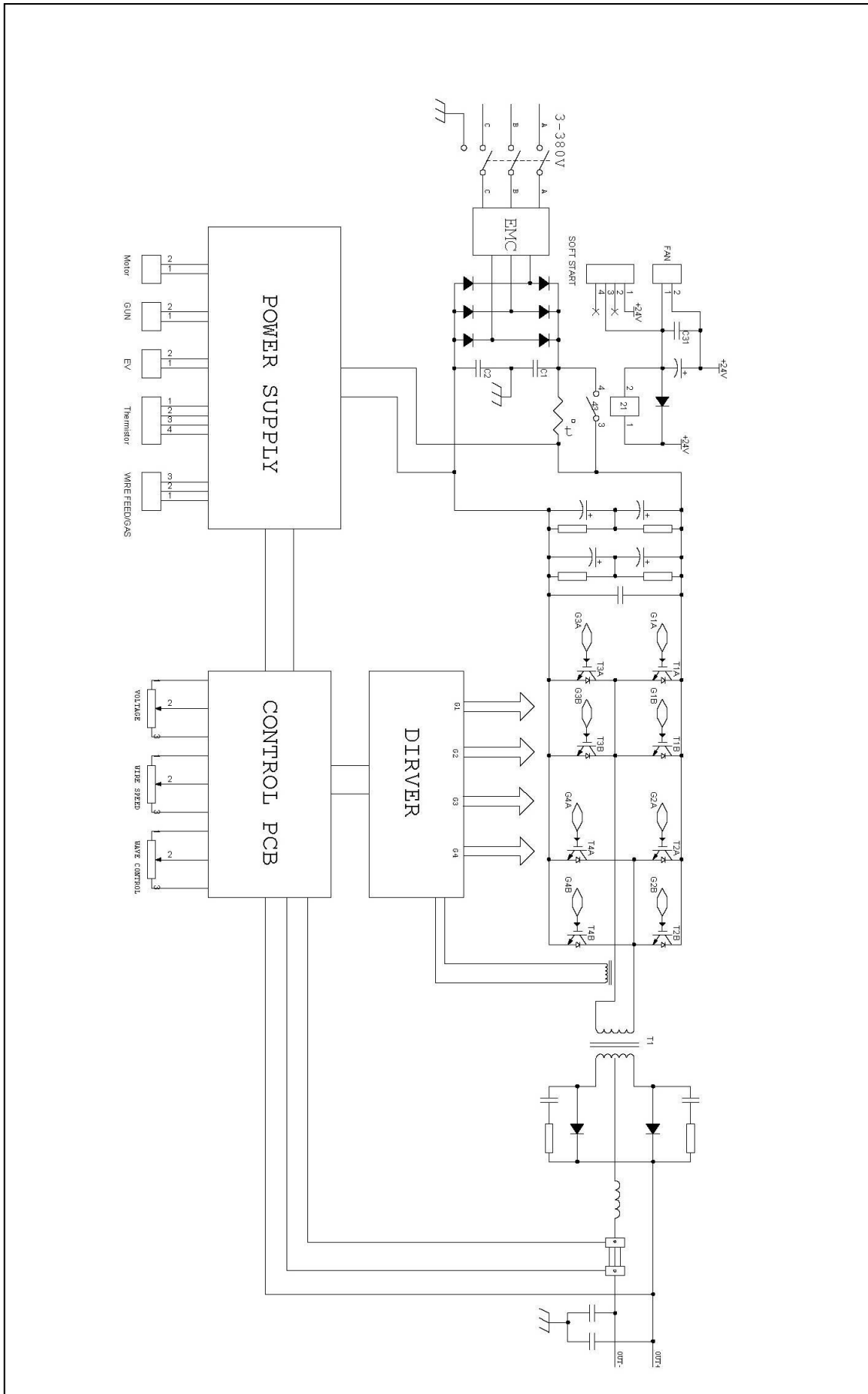

EU-Konformitätserklärung

Name des Hersteller / Inverkehrbringer: MK Trade GmbH

Anschrift des Hersteller / Inverkehrbringer: Radlpaßstraße 21
A-8551 Wies

Produkt Marke: MK Welding

Produkt Gruppe: Schweißgerät

Produkt Type: MIG/MAG Schweißgerät

Bezeichnung des Produktes: GMAW 315

Seriennummer*: **1.0003.0540-E**_____

Baujahr*: **20**_____ (Ersichtlich anhand der Seriennummer)

* anhand des Typenschildes am Gerät Auszufüllen

Das oben genannte Erzeugnis stimmt mit den Vorschriften folgender Europäischen Richtlinien überein:

2014/30/EU
(EMV Richtlinie)

2014/35/EU
(elektrischer Betriebsmittel zur Verwendung innerhalb bestimmter Spannungsgrenzen)

Die oben genannten Erzeugnisse stimmen mit den Vorschriften dieser Richtlinie überein und entsprechen den Sicherheitsanforderungen für Einrichtungen zum Lichtbogenschweißen gemäß den folgenden Produkt Normen.

Folgende harmonisierte Europäische Normen wurden angewandt:

EN 60 974-1:2012	Lichtbogenschweißeinrichtungen / Teil 1: Schweißstromquellen
EN 60 974-10:2014 +A1:2015 Verträglichkeit	Lichtbogenschweißeinrichtungen / Teil 10: Elektromagnetische Anforderungen (EMV)

Gemäß EG-Richtlinie 2006/42/EG Artikel 1 fallen oben genannte Erzeugnisse ausschließlich in den Anwendungsbereich der Richtlinie **2014/35/EU** betreffend elektrischer Betriebsmittel zur Verwendung innerhalb bestimmter Spannungsgrenzen.

Elektromagnetische Verträglichkeit (EMV) (EN 60 974-10)

Das Gerät ist gemäß der Norm EN 60974-10 in Klasse A gebaut und geprüft. Diese Klasse A Schweißeinrichtung ist für den Einsatz in industrieller Umgebung und nicht für den Einsatz in Wohnbereichen vorgesehen.

Datum:

Wies, 01.05.2020

Unterschrift



Geschäftsführer, M. Knappitsch